



PARTS DRAWING



**13hp Hydraulic Rear
Tine Tiller**

**Product Code:
BAR1320**



Serial Number Range:

From:

To:

Year Of Manufacture: 2008

***Please note, when ordering online via our website if the part number is not recognised,
please Email spares@hscgroupuk.co.uk or Telephone 0115 946 1988**

KEEP THIS BOOKLET FOR FUTURE REFERENCE

Nottingham: 0115 946 1988 • London: 0208 830 3333 ✉ Nottingham: sales@hscgroupuk.co.uk • London: sean@hscgroupuk.co.uk 🌐 www.hscgroupuk.co.uk

The Hire Supply Company Terms & Conditions Apply At All Time E&OE

REF. QTY.	PART NO.	DESCRIPTION
1	04016	ACTUATOR VALVE, O-RING PORTS
2	05028	C-CLIP, 3/4"
3	03055	SPRING, VALVE SPOOL RETURN
4	03056	COLLAR, 3/8 ID
5	05108	WASHER, 3/8 USS, ZINC
6	05092	HH CAP SCREW, 3/8-16 NC X 1-1/2 G5 ZINC
7	04567	FITTING, 6407-8-8
8	03077	O-RING, -8 FITTING
9	04008-BO	RELIEF VALVE, 3000 POUND, O-RING
10	10481	RETURN TUBE, #8 O-RING

⑩ FOR 1620, USE PART NO. 04008-CO (3500 POUND RELIEF VALVE).

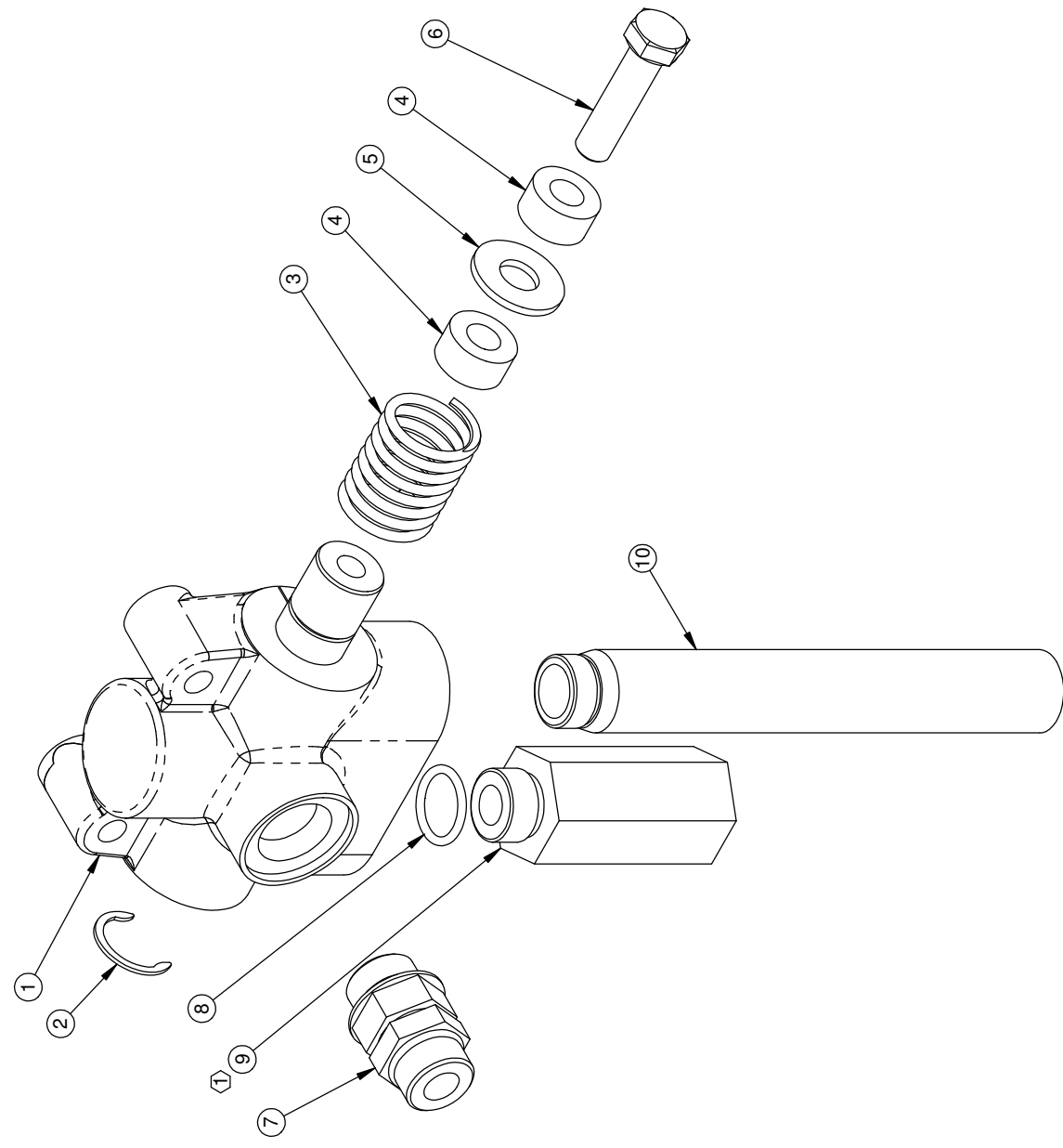

TITLE: ACTUATOR VALVE

PRODUCT LINE: 1320 & 1620 DATE: 1/4/05

SCALE: 1:1.8 SHEET 1 OF 1 DWG# 00277

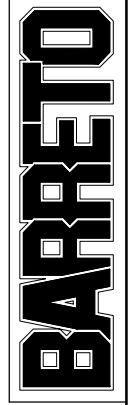

REF. QTY.	PART NO.	DESCRIPTION
1	10804	AXLE, FREE WHEEL HUBS ONLY
2	05044	GREASE ZERK, 1/4-28 UNF
3	05606	SNAP RING, 1-1/8" EXTERNAL
4	03008	THRUST WASHER, 1-1/8 X 1-3/4 X .030
5	03013	FELT WASHER, 1-1/8 X 2 X 1/8
6	05018	KEY, 1/4 X 1/4 X 1-1/4 HARDENED
7	03039	THRUST WASHER, 1-1/8 X 1-3/4 X .060
8	05033	HAIR SPRING COTTER P2
9	02006-F	SPROCKET, #50 40 TOOTH
10	03015-L	#50 ROLLER CHAIN, 63 PITCH WITH MASTER

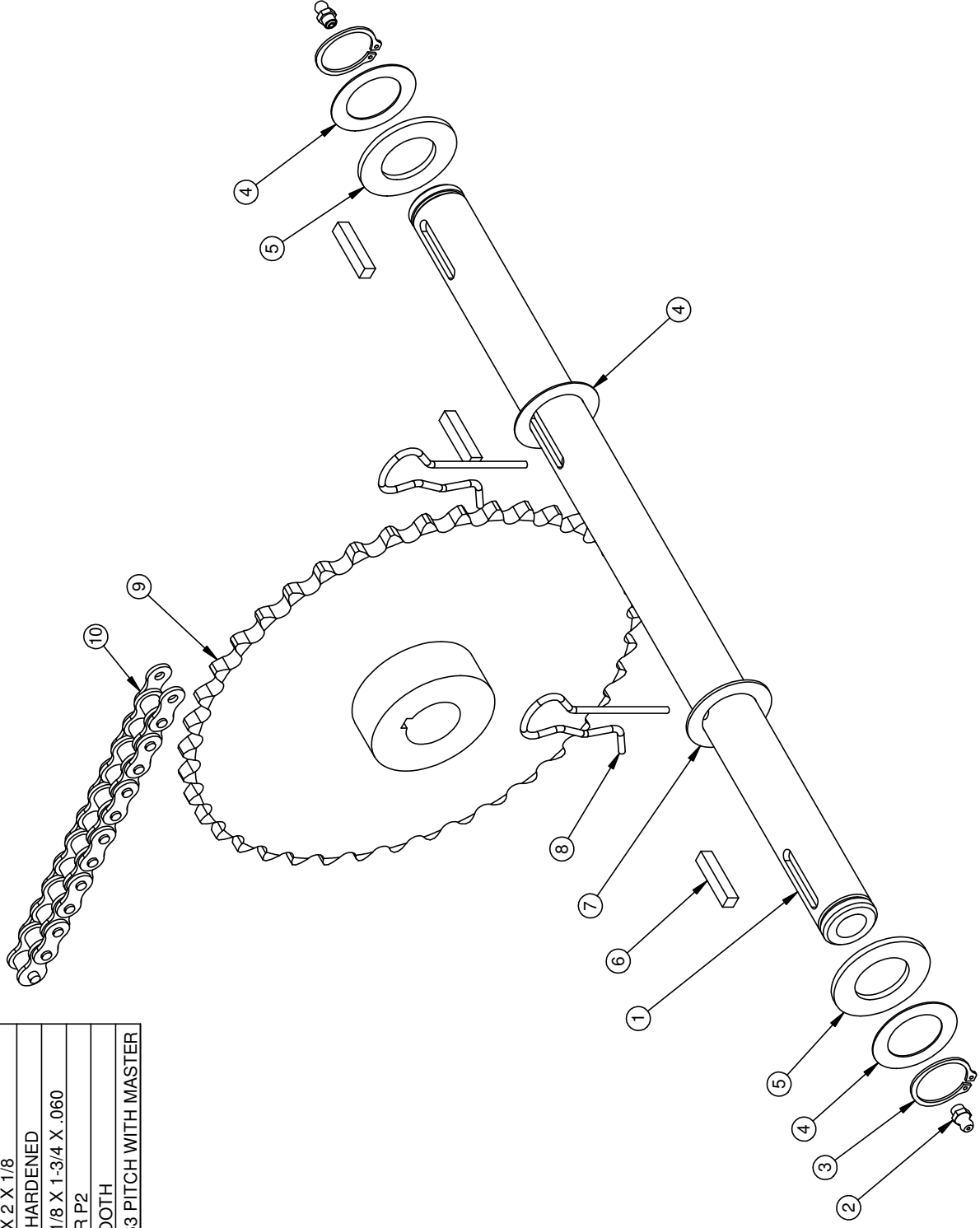

BARRETO

TITLE: AXLE,
FOR 1-1/8" FREE WHEEL HUBS
PRODUCT LINE: 1320 & 1620 7/21/05
SCALE: 1:3
SHEET 1 OF 1 DWG# 00278 R1

REF. QTY.	PART NO.	DESCRIPTION
1	10532	BODY
2	03007	BUSHING, AXLE
3	03012	SEAL, AXLE
4	10361	FITTING, 6409-8 PLUG
5	10536	TORQUE TUBE, 21"
6	05046	NUT, GRIPCO, 1/2-13 NC
7	05067	HH CAP SCREW, 1/2-13 NC X 1 G5 ZINC
8	03040-10	DECAL, "1320"
9	04221	FITTING, 6900-12-12
10	03951	FILTER, HYDRAULIC OIL, WITH BY-PASS
11	04403	FILTER HEAD, #12 O-RING
12	04222	FITTING, 6410-12-8
13	03060	BUSHING, IGUS MFI-1012-06
14	03020	SEAL
15	03061	FELT WASHER, 5/8 X 1 X 1/8
16	05096	NUT, NYLOCK, 1/4-20 NC
17	01038	ACTUATOR ARM
18	01037	ACTUATOR PLATE
19	05125	HH CAP SCREW, 1/4-20 NC X 1-1/4 G5 ZINC
20	03040-11	DECAL, "BARRETO", 2-3/16 X 7-3/8
21	03041	GASKET, TILLER LID
22	03503	SIGHT GAUGE
23	03040-57	DECAL, "HYDRAULIC OIL LEVEL"
24	01022	LID
25	05069	WHIZ LOCK, 1/4-20 NC X 5/8 ZINC
26	03520	MAGNET
27	05056	HH CAP SCREW, 3/8-24 NF X 1 G5 ZINC
28	05101	WASHER, 3/8 SAE ZINC
29	05072	NUT, NYLOCK, 3/8-24 NF
30	04517 R1	BREATHER HOSE ASSEMBLY
31	03040-06	DECAL, "HYDRAULIC OIL ONLY"
32	10526	FITTING, 6409-12 PLUG
33	05090	NUT, 1/4-20 NC ZINC
34	05237	HH CAP SCREW, 1/4-20 NC X 1 G5 ZINC
35	03000	O-RING, 2-234, 3-1/4 OD X 1/8 SECTION
36	02004	WHEEL MOTOR SPACER
37	03001	O-RING, 2-152, 3-7/16 OD X 3/32 SECTION
38	02014	SPROCKET, #50 10 TOOTH
39	05021	SET SCREW, 1/4-20 UNC X 5/16, CUP POINT
40	04557	FITTING, 6802-8-10
41	04003-F	WHEEL DRIVE MOTOR WITH KEY
42	05102	WASHER, 1/2 SAE ZINC HARDENED
43	05098	NUT, NYLOCK, 1/2-13 NC
44	05092	HH CAP SCREW, 3/8-16 NC X 1-1/2 G5 ZINC
45	07007	ENGINE, 13 HP HONDA GX390 CYCLONE AIR
46	01033-B	ENGINE GUARD, 1320
47	06422	IGNITION WIRE, 78"
48	03035	TIE WRAP, 1/8 X 6
49	03806	QUICK-SPLICE

- ① NOT USED FOR 1620.
- ② REPLACEMENT KEY IS PART NO. 05013 (1/4 X 1 WOODRUFF KEY).
- ③ FOR 1620, ENGINE IS PART NO. 07000 (16 HP B&S VANGUARD). SEE ALSO DWG. 00281 (FUEL TANK & ENGINE MOUNT, 1620).
- ④ FOR 1620, USE PART NO. 10561 (IGNITION WIRE, 1620).
- ⑤ FOR 1620, USE PART NO. 10644 (ENGINE GUARD, 1620).
- ⑥ PART NO. 01021 (HANDLE BAR MOUNT) ALTHOUGH WELDED TO THE BODY, IS AVAILABLE SEPARATELY.

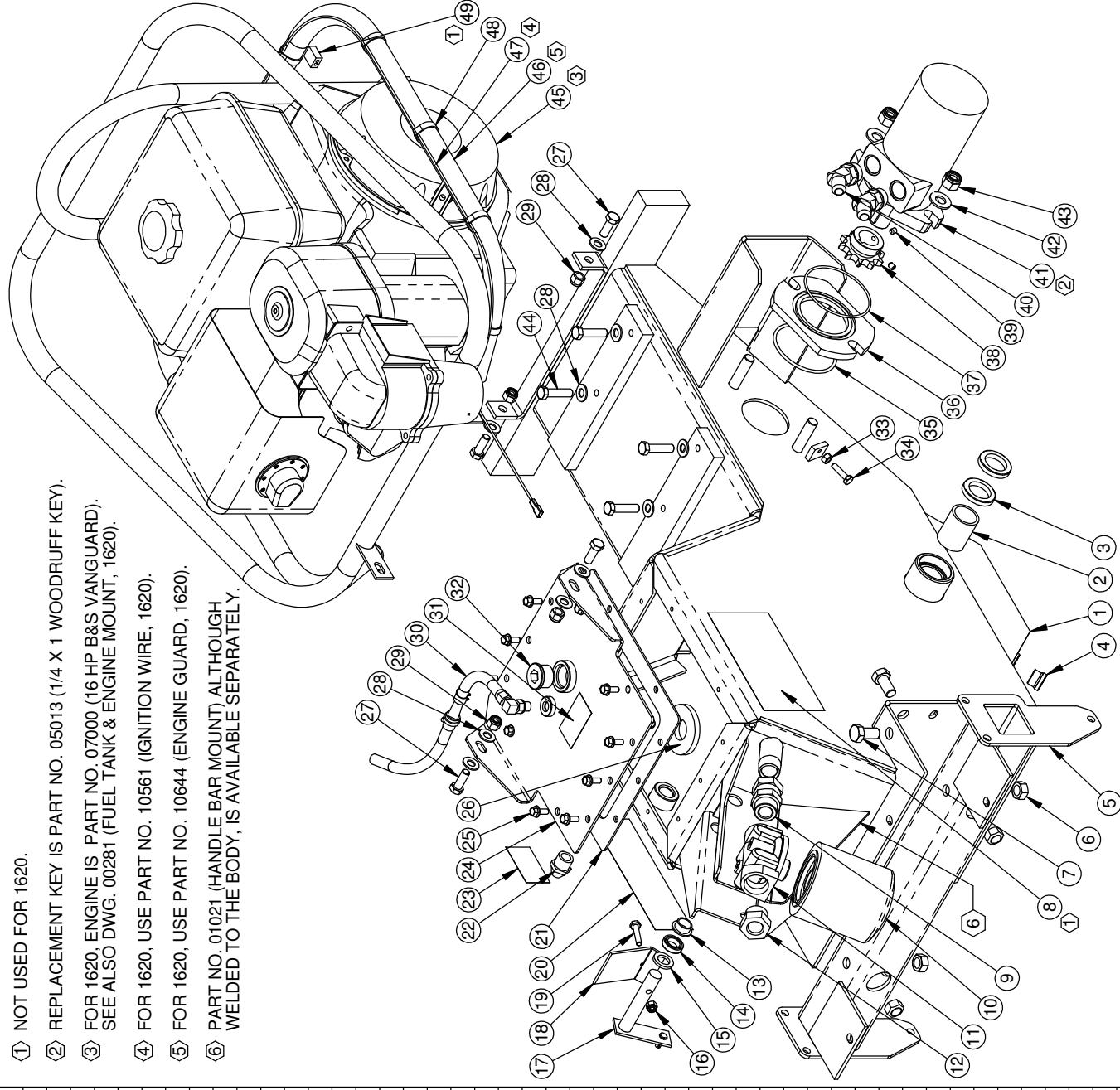

TITLE: BODY

BARRETO

PRODUCT LINE: 1320 & 1620 DATE: 1/29/07

SCALE: 17.5

DWG# 00279 R5

SHEET 1 OF 1

REF.	QTY.	PART NO.	DESCRIPTION
1	1	04010	CONTROL VALVE BODY (ORDER 04010-K)
2	4	05200	ROLL PIN (SLOTTED SPRING), 1/4 X 1-1/4 ZINC
3	1	06421	GROUND WIRE, IGNITION SWITCH
4	2	05273	NUT, NYLOCK, 5/16-18 NC ZINC
5	2	03027	DETENT SPRING
6	2	02017	HANDLE, 5/16 X 7
7	1	04015-D	VALVE SPOOL, TINES (ORDER 04010-K)
8	4	03002	O-RING, 2-210, 1" OD X 1/8 SECTION
9	4	03025	BACK-UP RING, 1" TEFLON
10	4	05010	SNAP RING, 1" EXTERNAL
11	2	05573	SH CAP SCREW, 1/4-20 NC X 3/8 ZINC
12	2	04554	FITTING, 6801-8-8
13	2	03026	KNOB, 5/16-NC
14	1	03040	DECAL, CONTROL VALVE
15	3	04520	FITTING, 6400-8-8
16	1	05023	PIPE PLUG, 1/8"
17	4	03300	FITTING, 6409-4 PLUG
18	2	05065	HH CAP SCREW, 5/16-18 NC X 2-3/4 G5 ZINC
19	1	04015-C	VALVE SPOOL, WHEEL DRIVE (ORDER 04010-K)
20	1	04308	HOSE, CONTROL VALVE TO ACTUATOR TEE FITTING
21	1	04309	HOSE, CONTROL VALVE TO TINE MOTOR LOWER PORT
22	1	04310	HOSE, CONTROL VALVE TO TINE MOTOR UPPER PORT
23	1	04311	HOSE, CONTROL VALVE TO WHEEL MOTOR LOWER PORT
24	1	04312	HOSE, CONTROL VALVE TO WHEEL MOTOR UPPER PORT
25	1	04313	HOSE, CONTROL VALVE TO OIL FILTER MOUNT

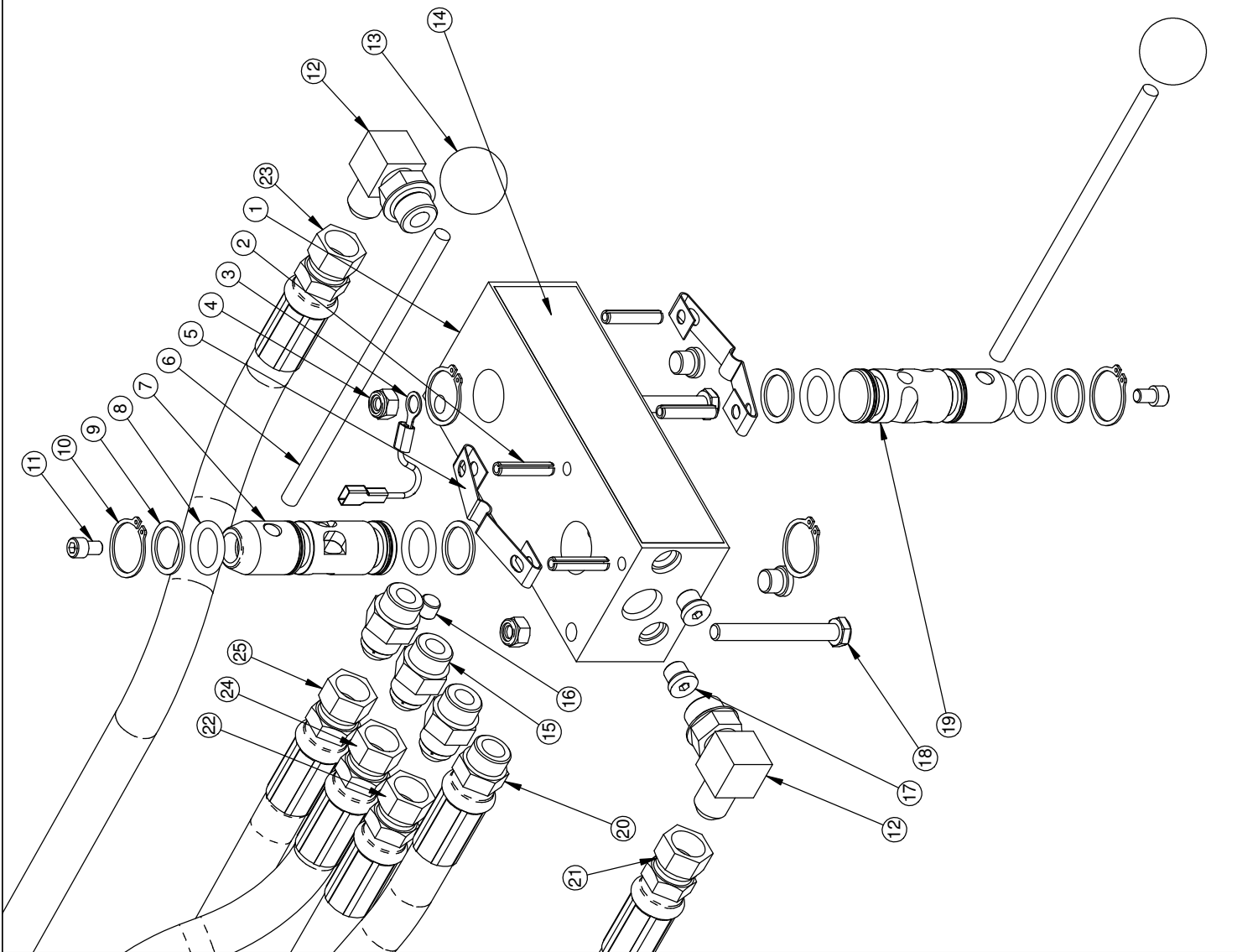

BARRETO

TITLE: CONTROL VALVE

PRODUCT LINE: 1320 & 1620 DATE: 4/26/07

SCALE: 1:3 DWG# 00280 R2
SHEET 1 OF 1

REF. QTY.	PART NO.	DESCRIPTION
1	2	05297 HH CAP SCREW, 5/16-18 NC X 1-1/4 G5 ZINC
2	4	10615 WASHER, 5/16 USS ZINC
3	1	10556 MOUNTING BRACKET, FUEL TANK
4	1	10559 FUEL TANK, 1620, INCLUDES KELCH CAP
5	6	05273 NUT, NYLOCK, 5/16-18 NC ZINC
6	1	05131 HH FLANGE SCREW, 5/16-18 NC X 3/4 G8 ZINC
7	1	03062-04 FITTING, 1/8 NPT TO 1/4 HOSE BIB, STRAIGHT
8	4	03062-06 CLAMP, 1/4" FUEL LINE
9	1	11346 HOSE, 1/4" GASOLINE, 4L5, 3 LONG
10	1	03062-03 FUEL SHUT OFF VALVE
11	1	11352 HOSE, 1/4" GASOLINE, 4L5, 24 LONG
12	1	03062-12 FUEL TANK CAP, KELCH
13	2	01014 SPACER, ENGINE
14	4	05068 WASHER, 5/16 SAE ZINC
15	4	05101 WASHER, 3/8 SAE ZINC
16	4	05057 HH CAP SCREW, 3/8-16 NC X 3/4 G5 ZINC
17	1	01013 MOUNTING PLATE, 16 HP B&S ENGINE
18	1	07000-01 MUFFLER, B&S 16HP VANGUARD
19	1	07000-02 CLAMP, MUFFLER, WITH CARRIAGE BOLT & NUT
20	1	07000-03 MOUNTING BRACKET, MUFFLER
21	1	07000-04 MANIFOLD WITH GASKETS & FASTENERS
22	2	03070 SCREW, 6MM
23	2	03071 SCREW, 8MM
24	2	05041 HOSE CLAMP, 1" SS
25	1	01040 HEAT SHIELD, 16 HP B&S ENGINE

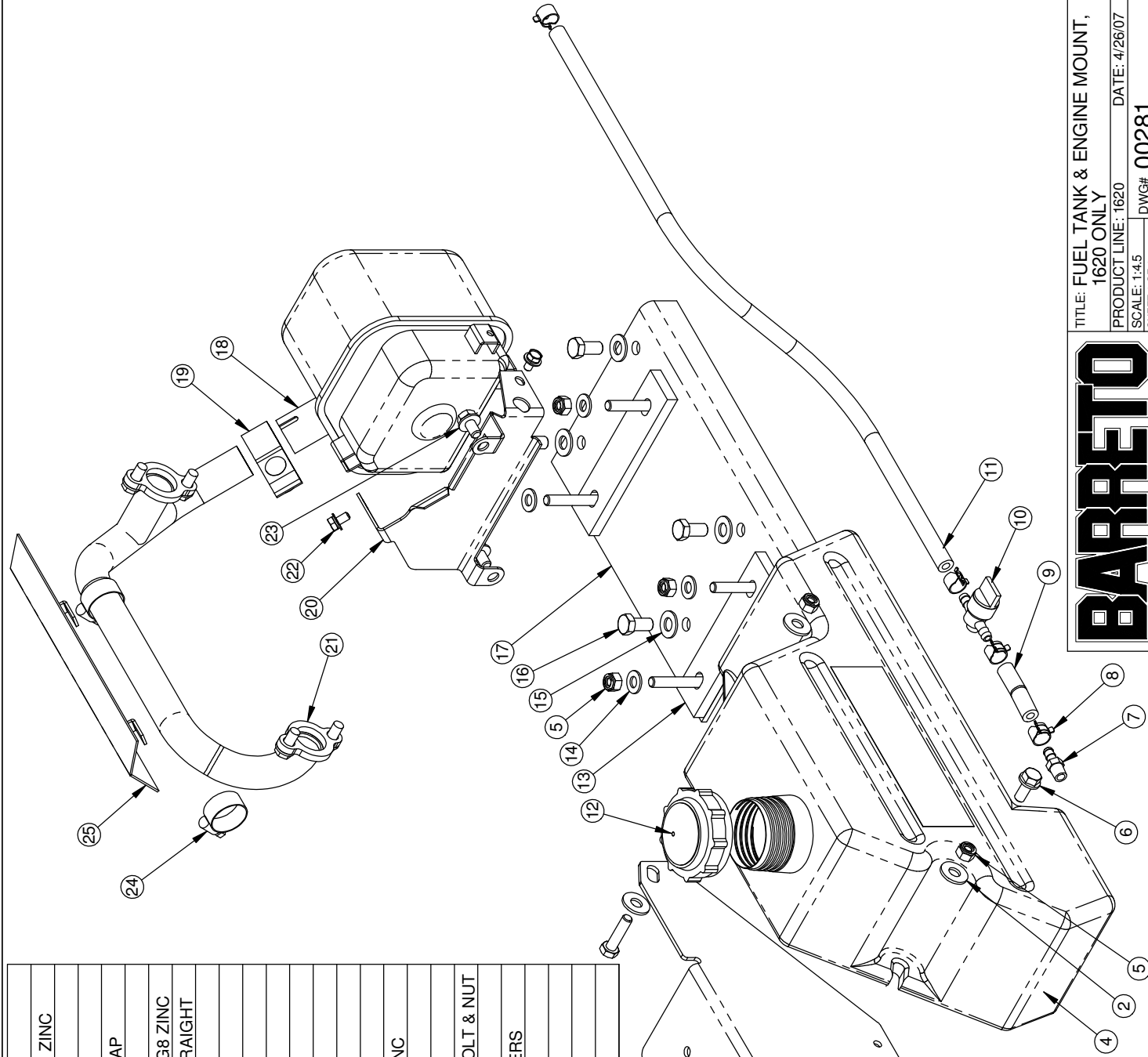

BARRETO

TITLE: FUEL TANK & ENGINE MOUNT,
1620 ONLY

PRODUCT LINE: 1620

SCALE: 1:4.5

SHEET 1 OF 1

DATE: 4/26/07

DWG# 00281

REF. QTY.	PART NO.	DESCRIPTION	REF. QTY.	PART NO.	DESCRIPTION
1	01017	HANDLE BARS	14	03029	LEVER ASSEMBLY (COMPLETE)
2	02027-L	HANDLE BAR ADJUSTER PIN, LOWER	15	03045	CABLE, ACTUATOR
3	05216	SNAP RING, 3/4 EXTERNAL	16	05081	WASHER, 1/4 SAE ZINC
4	03501	BUSHING, IGUS MFI-0810-08	17	05039	CIRCLE COTTER CC-3
5	05102	WASHER, 1/2 SAE ZINC HARDENED	18	03009	HOUR METER - COMPLETE KIT
6	05093	HH CAP SCREW, 1/2-13 NC X 3 G5 ZINC	19	03341-07	DECAL, "IGNITION OFF/ON"
7	05098	NUT, NYLOCK, 1/2-13 NC	20	06420	ROCKER SWITCH, IGNITION OFF/ON
8	01030	CRANK, HANDLE BAR ADJUSTMENT	21	10667	HOSE KEEPER
9	05058	WASHER, 3/8 NYLON	22	10668	SPACER, HOSE KEEPER
10	05103	WASHER, 3/8 A325 HARDENED ZINC	23	05065	HH CAP SCREW, 5/16-18 NC X 2-3/4 G5 ZINC
11	02027-U	PIN, HANDLE BAR ADJUSTMENT, UPPER	24	05068	WASHER, 5/16 SAE ZINC
12	05269	NUT, 3/8-16 NC GRB ZINC	25	05273	NUT, NYLOCK, 5/16-18 NC
13	03032-01	GRIP, 1 X 5 (P/N 03032 IS A PAIR)			

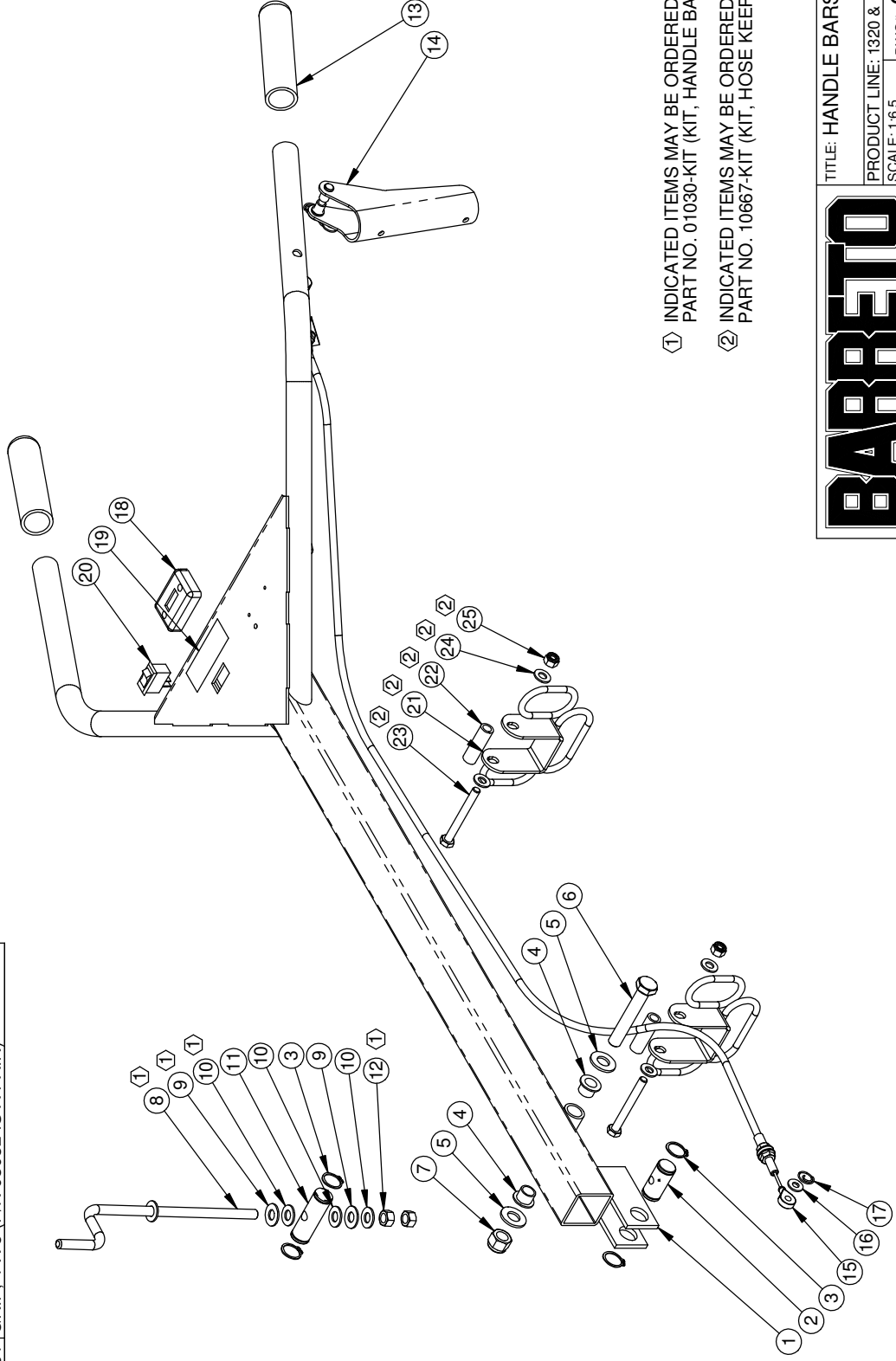

- ① INDICATED ITEMS MAY BE ORDERED AS A KIT, PART NO. 01030-KIT (KIT, HANDLE BAR ADJUSTMENT).
- ② INDICATED ITEMS MAY BE ORDERED AS A KIT, PART NO. 10667-KIT (KIT, HOSE KEEPER W/FASTENERS).

BARRETO

TITLE: HANDLE BARS & CRANK

PRODUCT LINE: 1320 & 1620 1/16/07
SCALE: 1:6.5 DWG# 00282 R1
SHEET 1 OF 1

NOTES:

- ① COMES WITH SET SCREW. REPLACEMENT SET SCREW IS PART NO. 05020 (1/4 X 1/4 NC).
- ② COMES WITH SET SCREW. REPLACEMENT SET SCREW IS PART NO. 05127 (5/16 X 5/16 NC).
- ③ FOR 1620, USE PART NO. 05014 (1/4 X 1/4 X 3/4 KEY).
- ④ FOR 1620, USE PART NO. 04301 (HOSE, INTAKE, 1620).
- ⑤ FOR 1620, USE PART NO. 04305 (HOSE, PUMP TO TEE, 1620).
- ⑥ FOR 1620, QUANTITY OF 04304 IS ONE.

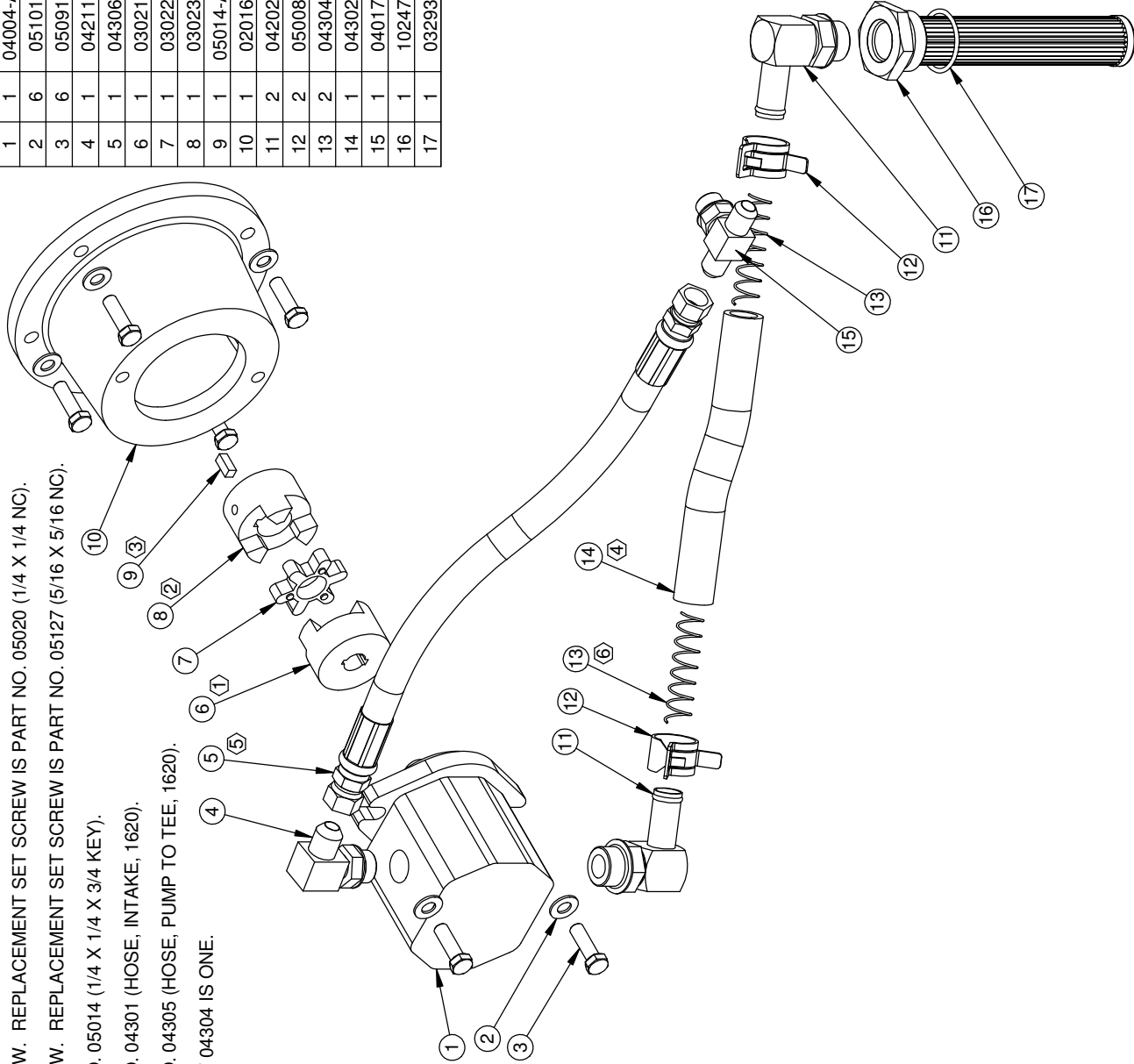

REF.	QTY.	PART NO.	DESCRIPTION
1	1	04004-A	PUMP, HYDRAULIC
2	6	05101	WASHER, 3/8 SAE ZINC
3	6	05091	HH CAP SCREW, 3/8-16 NC X 1-1/4 G5 ZINC
4	1	04211	FITTING, 6801-8-10
5	1	04306	HOSE, PUMP TO TEE, 1320
6	1	03021	JAW COUPLER, PUMP, 5/8" BORE
7	1	03022	SPIDER, RUBBER
8	1	03023	JAW COUPLER, 1" BORE L095
9	1	05014-A	KEY, 1/4 X 1/4 X 5/8
10	1	02016	PUMP ADAPTER
11	2	04202	FITTING, 4601-12-12
12	2	05008	CLAMP, 1" HOSE, CTB-29
13	2	04304	SPRING, 3/4" INTAKE HOSE
14	1	04302	HOSE, INTAKE, 1320
15	1	04017	FITTING, 6803-8-8-8
16	1	10247	SUMP SCREEN #20 EXT #12 INT O-RING
17	1	03293	O-RING, 3-920N90, -20 FITTINGS

TITLE: PUMP

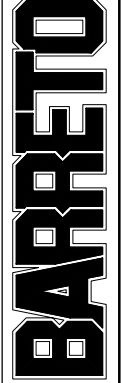

PRODUCT LINE: 1320 & 1620 DATE: 9/5/07
 SCALE: 1:4.5 DWG# 00283 R1
 SHEET 1 OF 1

REF. QTY.	PART NO.	DESCRIPTION
1	10539	LH SIDE PLATE, TINE SECTION
2	05056	HH CAP SCREW, 3/8-24 NF X 1 G5 ZINC
3	05072	NUT, NYLOCK, 3/8-24 NF
4	05300-01	HH CAP SCREW, 1/2-13 NC X 1-1/2 G5 ZINC
5	01009	TINE MOTOR MOUNTING BRACKET
6	04000T-F	TINE MOTOR, 6.2 CU IN WITH KEY & NUT
7	05098	NUT, NYLOCK, 1/2-13 NC
8	04209	FITTING, 6410-10-8
9	04210	FITTING, 6802-8-8
10	04211	FITTING, 6801-8-10
11	01024	TINE MOTOR GUARD
12	05292	HH CAP SCREW, 3/8-24 NF X 1-1/4 G5 ZINC
13	05063	HH CAP SCREW, 7/16-20 NF X 1-1/4 G8 ZINC
14	01010-SGT	TINE MOTOR HUB, TAPERED BORE
15	01011	TINE SHAFT
16	03006-L	LH TINE, HARDFACED
17	03006-R	RH TINE, HARDFACED
18	05074	NUT, 7/16-20 NF G8 ZINC
19	05061	HH CAP SCREW, 7/16-20 NF X 1 G8 ZINC
20	10144	OUTBOARD BEARING ASSEMBLY
21	05103	WASHER, 3/8 A325 HARDENED ZINC
22	05083	WASHER, 7/16 USS ZINC
23	05059	HH CAP SCREW, 3/8-16 NC X 1 G5 ZINC
24	10538	RH SIDE PLATE, TINE SECTION
25	05044	GREASE ZERK, 1/4-28 UNF
26	01008	TINE COVER, 1320/1620
27	05140	WHIZ LOCK, 5/16 x 3/4
28	05273	NUT, NYLOCK, 5/16-18 NC
29	01012	DEPTH BAR
30	05006	ROLL PIN (SLOTTED SPRING), 3/8 X 1-1/2 ZINC
31	05092	HH CAP SCREW, 3/8-16 NC X 1-1/2 G5 ZINC
32	01099	HANDLE, DEPTH BAR
33	05073	NUT, NYLOCK, 3/8-16 NC
34	03018	GRIP
35	03080	SPRING
36	01018	PIN, DEPTH BAR
37	03065	HAIR SPRING COTTER #4
38	03040-01	DECAL, "MADE IN USA"
39	03040-02	DECAL, "BARRETO", 3-1/2 X 11-1/4
40	03040-03	DECAL, "CAUTION" (BLACK & WHITE)
41	03040-04	DECAL, "GREASE DAILY"
42	03040-07	DECAL, "CAUTION" (YELLOW)
43	03040-08	DECAL, "WARNING" (YELLOW)
44	03040-11	DECAL, "BARRETO", 2-3/16 X 7-3/8
45	03341-22	DECAL, "TILLER OPERATING INSTRUCTIONS"
46	03341-23	DECAL, "TILLER SAFETY INSTRUCTIONS"

- ① PART NO. 05063-24 IS A SET OF 24 CAP SCREWS.
- ② PART NO. 03006-HF IS A COMPLETE SET OF 6 LH TINES AND 6 RH TINES.
- ③ PART NO. 05074-24 IS A SET OF 24 NUTS.
- ④ REFERENCE DWG. 10144 FOR INDIVIDUAL PARTS.
- ⑤ FOR 1620, SUBSTITUTE PART NO. 03040-09 (DECAL, "1620")

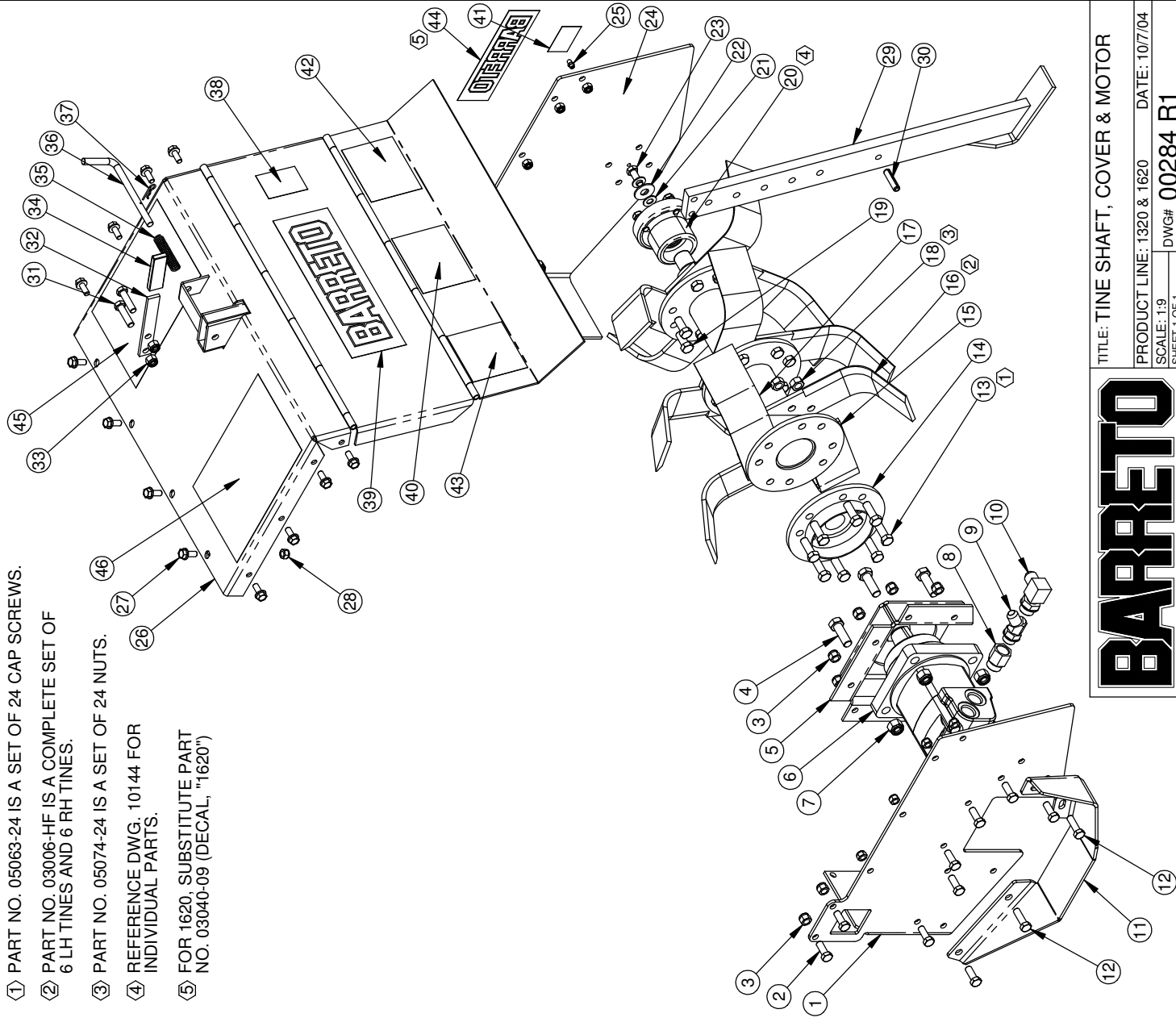

BARRETO

TITLE: TINE SHAFT, COVER & MOTOR

PRODUCT LINE: 1320 & 1620 DATE: 10/7/04

SCALE: 1:9

SHEET 1 OF 1

DWG# 00284 R1

REF. QTY.	PART NO.	DESCRIPTION
1	04555	FITTING, 6801-4-4
2	04214	FITTING, JS-4-4, HOSE BARB 1/4 X 1/4 SWIVEL
3	11350	HOSE, 1/4 INCH GASOLINE, 4L5, 5" LONG
4	03062-06	CLAMP, 1/4" FUEL LINE
5	04516	BREATHER, FILTER SNAPPER 1435
6	11351	HOSE, 1/4 INCH GASOLINE, 4L5, 8" LONG

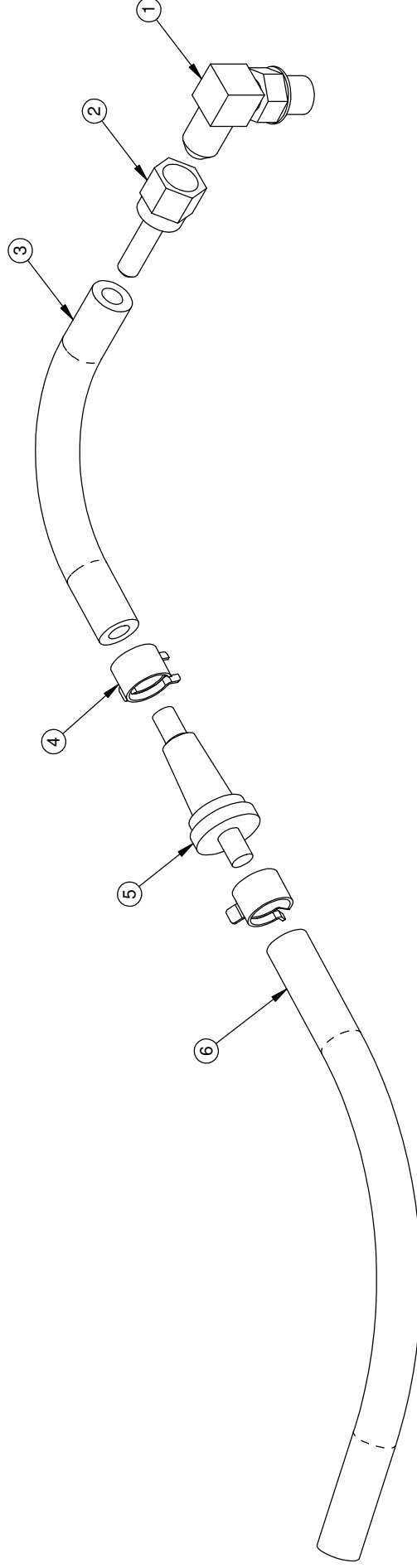

NOTES:

1. USAGE: 1 PER 1320 & 1620

BARRETO

TITLE: BREATHER HOSE ASSEMBLY

PRODUCT LINE: 1320 & 1620 DATE: 4/26/07

SCALE: 1:1.8
SHEET 1 OF 1

DWG# 04517 R1

REF	QTY.	PART NO.	DESCRIPTION
1	1	10142	OUTBOARD BEARING HOUSING, 4 BOLT
2	1	01026	SHIELD, OUTBOARD BEARING
3	2	03043	BALL BEARING, 6205
4	1	05024	SNAP RING, HO-200, 2" INTERNAL
5	1	03904	O-RING, 2-035, 2-3/8 OD X 1/16 SECTION
6	4	05059	HH CAP SCREW, 3/8-16 NC X 1 G5 ZINC

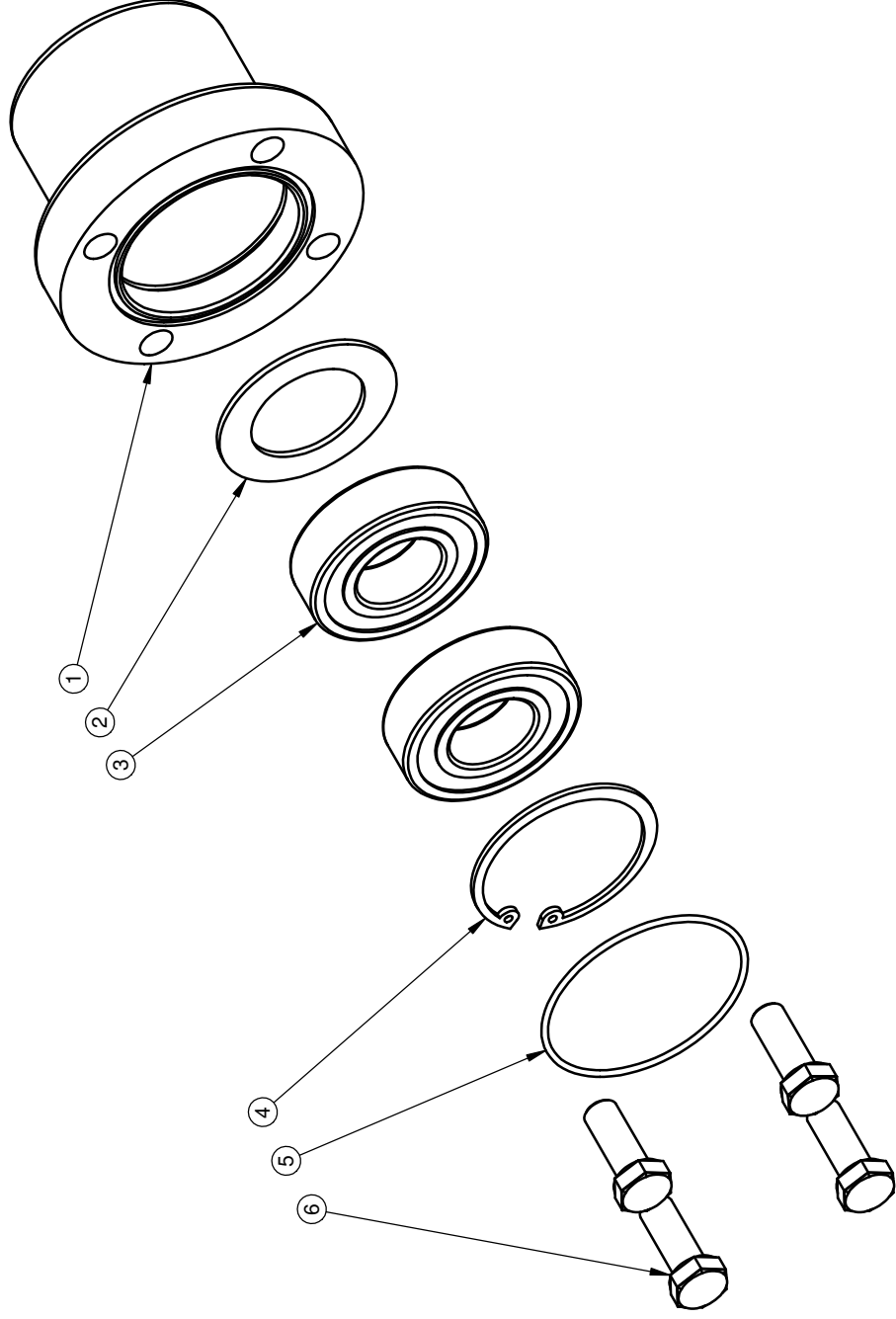

BARRETO

TITLE: OUTBOARD BEARING ASSEMBLY,
4 BOLT

PRODUCT LINE: COMMON DATE: 3/2/04

SCALE: 1:2 DWG# 10144

SHEET 1 OF 1

REF. QTY.	PART NO.	DESCRIPTION
1	2	02269-HUB
2	1	03047 WHEEL HUB ASSY, 1-1/8" BORE
3	1	03046 TIRE & RIM, TILLER RH, TRENCHER LH, 16 X 6.50 -8
4	2	05042 TIRE & RIM, TILLER LH, TRENCHER RH, 16 X 6.50 -8
5	2	02068 NUT, LUG, 1/2-20 NF
6	2	02068 PIN, FREE WHEELING
7	4	05102 WASHER, 1/2 SAE ZINC HARDENED
8	2	05548 ROLL PIN (SLOTTED SPRING), 1/8 X 3/4 ZINC
9	4	03352 SPRING, CENTURY 3385
10	4	02083 SPACER, WHEEL
11	2	01077 MOUNTING PLATE, PIN, FREE WHEELING
12	4	05076 NUT, GRIPCO, 1/2-20 NF G5 ZINC
12	2	03550 SPLIT RING-27

① REFERENCE DWG# 02269-HUB FOR INDIVIDUAL PARTS.

② RIM ALONE IS PART NO. 03049, TIRE ALONE IS PART NO. 03048.
CALL REGARDING OPTIONAL FOAM FILLED TIRES.

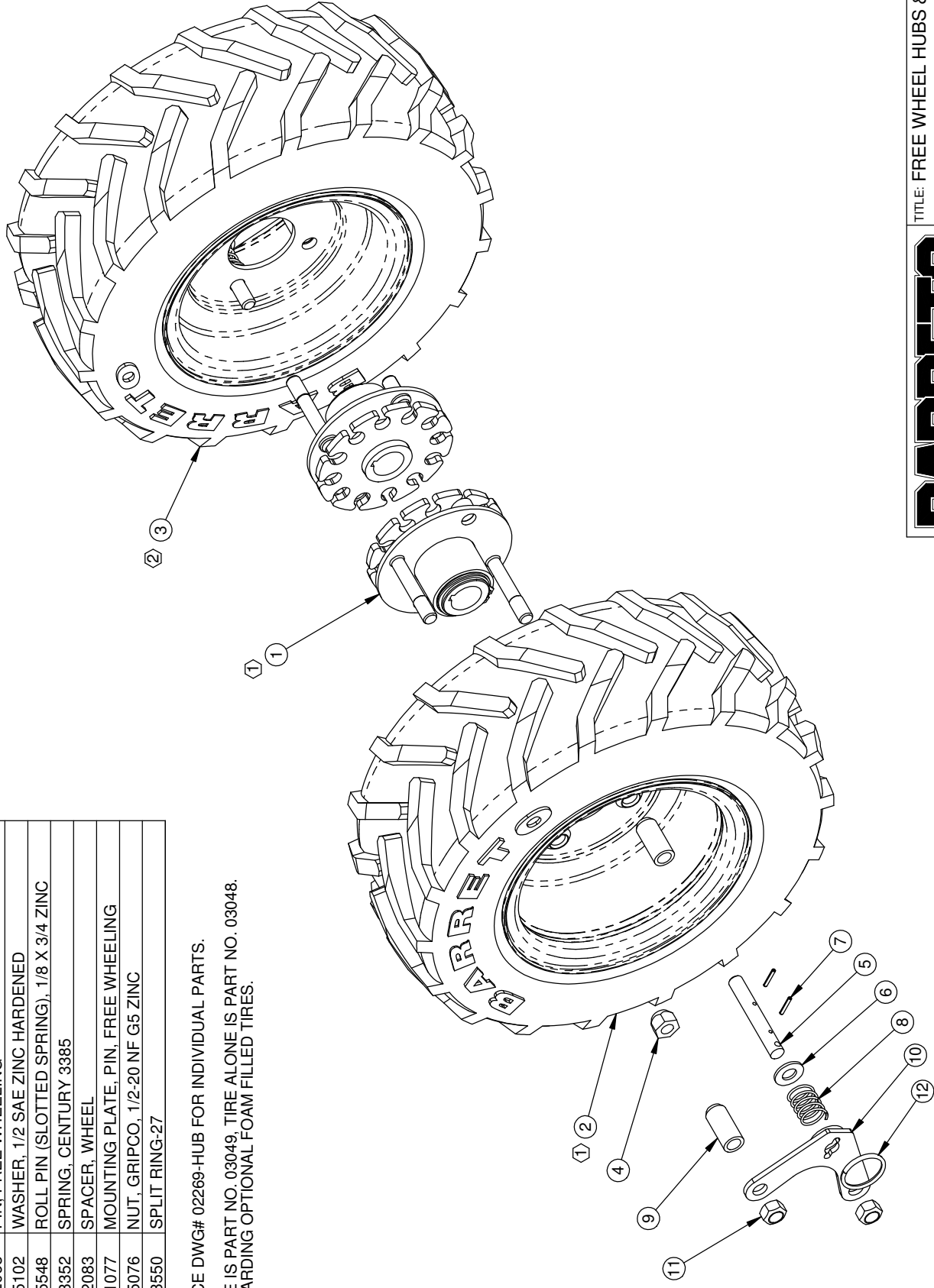

TITLE: FREE WHEEL HUBS & WHEELS

PRODUCT LINE: 1320 & 1620 DATE: 8/9/07

SCALE: 1:5

SHEET 1 OF 1 DWG# 10388

BARRETO



Recycling



ENVIRONMENTAL PROTECTION: Please recycle any unwanted materials as opposed to disposing them as general waste. It is recommended the original is retained and used to store the product when not in use for prolonged periods of time. If this is not applicable ensure the materials are sorted and recycled in accordance with local regulations.



SPECIFICATION CHANGE: It is our policy to continually improve products to ensure these meet the rigours of the industry we serve. Therefore, as such we reserve the right to alter specifications, data, components & parts with-out prior notice.

WARRANTY: Please refer to the manufactures terms & conditions.

IMPORTANT: No liability will be accepted for the incorrect use of this product.

KEEP THIS BOOKLET FOR FUTURE REFERENCE

📞 Nottingham: 0115 946 1988 • London: 0208 830 3333 ✉ Nottingham: sales@hscgroupuk.co.uk • London: sean@hscgroupuk.co.uk 🌐 www.hscgroupuk.co.uk

The Hire Supply Company Terms & Conditions Apply At All Time E&OE