



PARTS DRAWING



**13hp Hydraulic Rear
Tine Tiller**

**Product Code:
BAR1320**



Serial Number Range:

From:

To:

Year Of Manufacture: 2022

***Please note, when ordering online via our website if the part number is not recognised,
please Email spares@hscgroupuk.co.uk or Telephone 0115 946 1988**

KEEP THIS BOOKLET FOR FUTURE REFERENCE

Nottingham: 0115 946 1988 • London: 0208 830 3333 ✉ Nottingham: sales@hscgroupuk.co.uk • London: sean@hscgroupuk.co.uk 🌐 www.hscgroupuk.co.uk

The Hire Supply Company Terms & Conditions Apply At All Time E&OE

THE
BARRETO
MODEL E1320H/E1620B
HYDRAULIC REAR TINE TILLER
EXPLODED VIEWS WITH PART NUMBERS

CONGRATULATIONS!

You are now the proud owner of a BARRETO tiller. The following pages have detailed views of your tiller, along with corresponding part numbers. If you have any questions or need any replacement parts in the future, please contact us at your convenience. Our toll-free phone number, fax and email are listed below and parts may be ordered through any of these methods.

Thank you for your patronage and confidence in BARRETO equipment.

Barreto Manufacturing, Inc.
Innovative Equipment Engineered to Last
66498 Highway 203
La Grande, OR 97850
1-800-525-7348
1-541-963-6755 Fax
E-Mail: info@barretomfg.com
Web Site: <http://www.barretomfg.com>

Machine Identification Record

BARRETO Customer number _____
Machine model number _____
Machine serial number _____
Engine manufacturer _____
Engine model number _____
Engine serial number _____

REF QTY.	PART NO.	DESCRIPTION
1	04016	ACTUATOR VALVE, O-RING PORTS
2	05028	C-CLIP, 3/4", INCLUDED W/ ACTUATOR VALVE
3	03055	SPRING, VALVE SPOOL RETURN
4	03056	COLLAR, 3/8 ID
5	05108	WASHER, 3/8 USS, ZINC
6	05092	HH CAP SCREW, 3/8-16 NC X 1-1/2 G5 ZINC
7	04567	FITTING, 6407-8-8
8	03077	O-RING, 3-908N90, -8 FITTINGS
9	04008-BO	RELIEF VALVE, 3000 POUND, O-RING
10	10481	RETURN TUBE, #8 O-RING

Ⓜ FOR 1620, USE PART NO. 04008-CO (3500 POUND RELIEF VALVE).

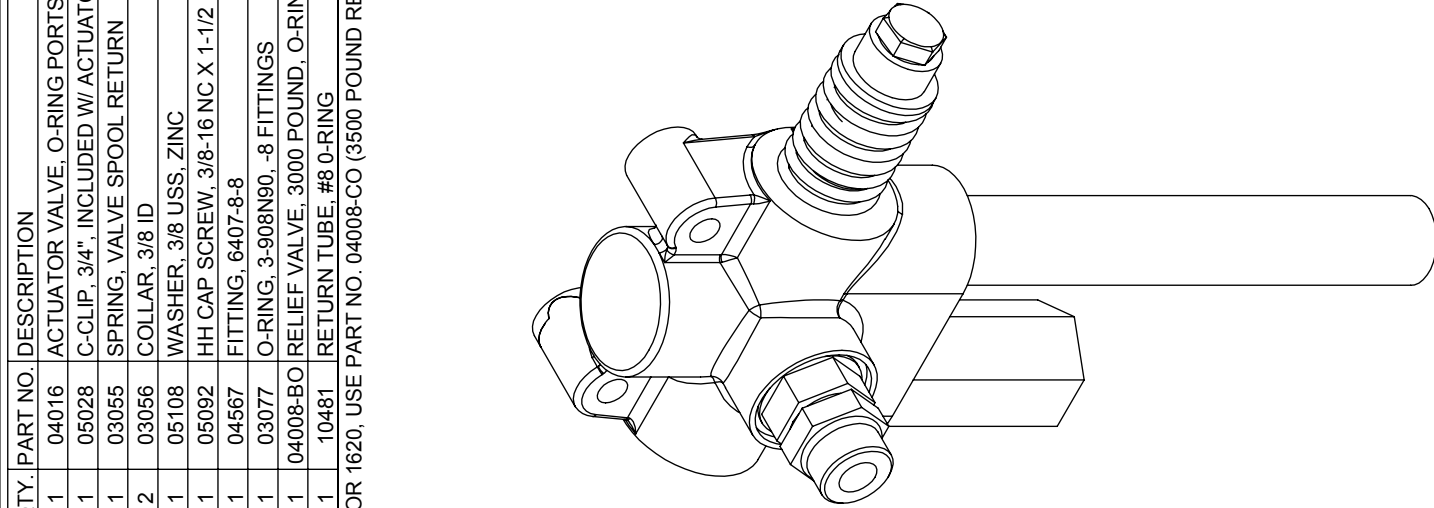
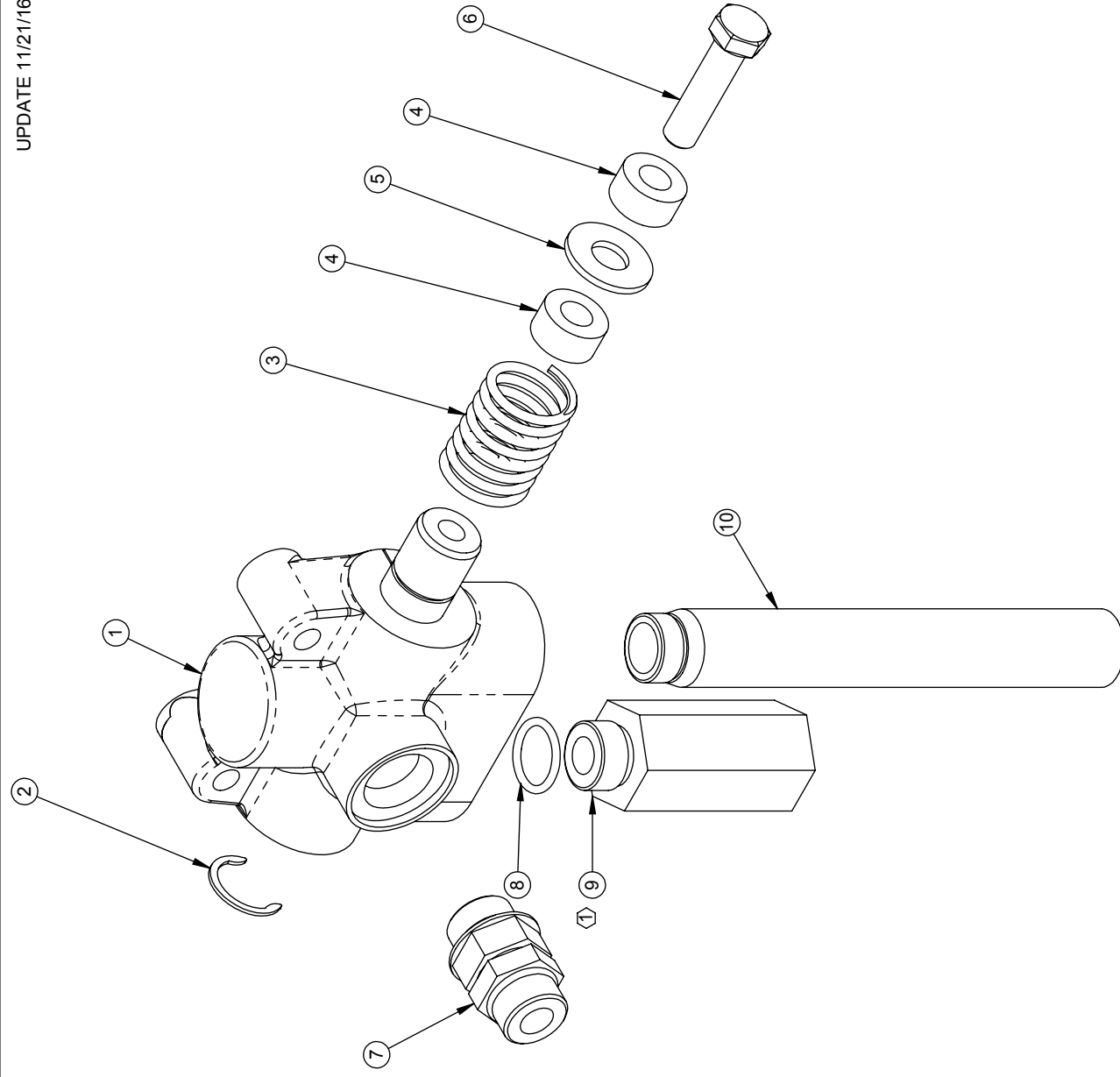

TITLE: ACTUATOR VALVE



PRODUCT LINE: 1320 & 1620 DATE: 1/4/05

SCALE: 1:1.8 SHEET 1 OF 2

DWG# 00277

UPDATED 11/21/16

REF	QTY.	PART NO.	DESCRIPTION
1	1	10804	AXLE, FREE WHEEL HUBS ONLY
2	1	02006-F	SPROCKET, #50 40 TOOTH
3	1	03015-L	#50 ROLLER CHAIN, 63 PITCH WITH MASTER
4	2	05044	GREASE ZERK, 1/4-28 UNF
5	2	05606	SNAP RING, 1-1/8" EXTERNAL
6	3	05018	KEY, 1/4 X 1/4 X 1-1/4 HARDENED
7	1	03008	THRUST WASHER, 1.136 X 1.784 X .032 HARD
8	2	03013	FELT WASHER, 1-1/8 X 2 X 1/8
9	1	03039	THRUST WASHER, 1-1/8 X 1-3/4 X .060
10	2	05033	HAIR SPRING COTTER P2

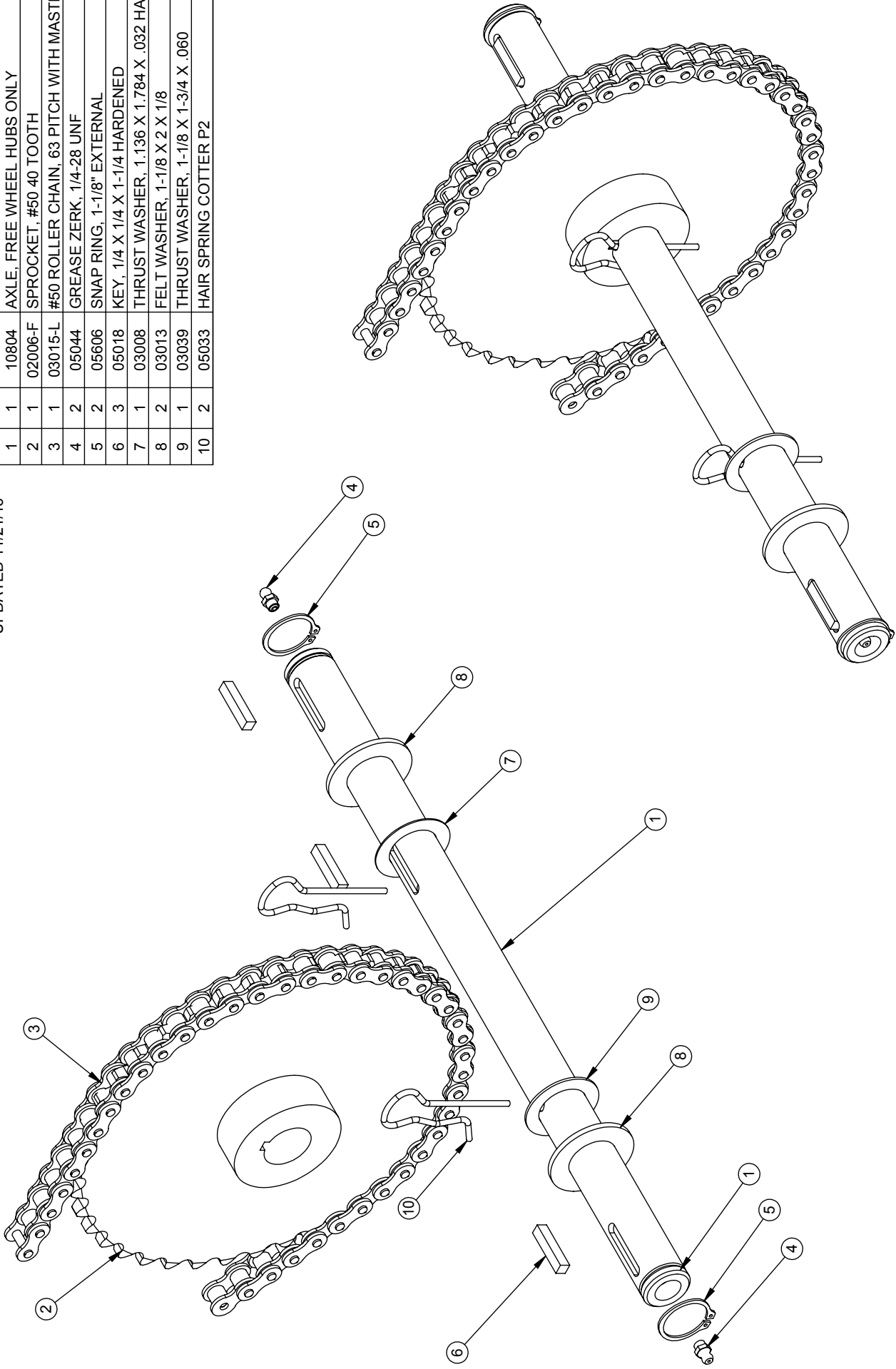

BARRETO

TITLE: AXLE,
FOR 1-1/8" FREE WHEEL HUBS
PRODUCT LINE: 1320 & 1620 7/21/05
SCALE: 1:3
SHEET 1 OF 1 DWG# 00278 R1

REF	QTY.	PART NO.	DESCRIPTION
1	1	10532	BODY
2	2	03007	BUSHING, AXLE
3	4	03012	SEAL, AXLE
4	1	10361	FITTING, 6409-8 PLUG
5	1	10536	TORQUE TUBE, 21"
6	4	05046	NUT, GRIPCO, 1/2-13 NC X 1 G5 ZINC
7	4	05067	HH CAP SCREW, 1/2-13 NC X 1 G5 ZINC
8	1	03040-10	DECAL, "1320"
9	1	04221	FITTING, 6900-12-12
10	1	03951	FILTER, HYDRAULIC OIL, WITH BY-PASS
11	1	04403	FILTER HEAD, #12 O-RING
12	1	10808	FITTING, 6400-8-12
13	2	03060	BUSHING, IGUS MFI-1012-06
14	1	03020	SEAL
15	1	03061	FELT WASHER, 5/8 X 1 X 1/8
16	1	05096	NUT, NYLOCK, 1/4-20 NC ZINC
17	1	01038	ACTUATOR ARM
18	1	01037	ACTUATOR PLATE
19	1	05125	HH CAP SCREW, 1/4-20 NC X 1-1/4 G5 ZINC
20	1	03040-11	DECAL, "BARRETO", 2-3/16 X 7-3/8
21	1	03041	GASKET, TILLER LID
22	1	03503	SIGHT GAUGE
23	1	03040-57	DECAL, "HYDRAULIC OIL LEVEL"
24	1	01022	LID
25	10	05069	WHIZ LOCK, 1/4-20 NC X 5/8 ZINC
26	1	03520	MAGNET
27	4	05056	HH CAP SCREW, 3/8-24 NF X 1 G5 ZINC
28	10	05101	WASHER, 3/8 SAE ZINC
29	4	05072	NUT, NYLOCK, 3/8-24 NF ZINC
30	1	04517 R1	BREATHER HOSE ASSEMBLY
31	1	03040-06	DECAL, "HYDRAULIC OIL ONLY"
32	1	10526	FITTING, 6409-12 PLUG
33	1	05090	NUT, 1/4-20 NC ZINC
34	1	05237	HH CAP SCREW, 1/4-20 NC X 1 G5 ZINC
35	1	03000	O-RING, 2-234, 3-1/4 OD X 1/8 SECTION
36	1	02004	WHEEL MOTOR SPACER
37	1	03001	O-RING, 2-152, 3-7/16 OD X 3/32 SECTION
38	1	02014	SPROCKET, #50 10 TOOTH
39	2	05021	SET SCREW, 1/4-20 UNC X 5/16, CUP POINT
40	2	04557	FITTING, 6802-8-10
41	1	04003-RR	WHEEL DRIVE MOTOR WITH KEY
42	2	05102	WASHER, 1/2 SAE ZINC HARDENED
43	4	05092	HH CAP SCREW, 3/8-16 NC X 1-1/2 G5 ZINC
44	1	07005	ENGINE, 13 HP HONDA GX390
45	1	01033-B	ENGINE GUARD, 1320
46	1	06422	IGNITION WIRE, 78"
47	5	03035	TIE WRAP, 1/8 X 6
48	1	03806	QUICK-SPLICE
49	2	05129	HH CAP SCREW, 1/2-13 NC X 1-3/4 G5 ZINC

- ① NOT USED FOR 1620.
- ② REPLACEMENT KEY IS PART NO. 05013 (1/4 X 1 WOODRUFF KEY).
- ③ FOR 1620, ENGINE IS PART NO. 07000 (16 HP B&S VANGUARD). SEE ALSO DWG. 00281 (FUEL TANK & ENGINE MOUNT, 1620).
- ④ FOR 1620, USE PART NO. 10561 (IGNITION WIRE, 1620).
- ⑤ FOR 1620, USE PART NO. 10644 (ENGINE GUARD, 1620).
- ⑥ PART NO. 01021 (HANDLE BAR MOUNT) ALTHOUGH WELDED TO THE BODY, IS AVAILABLE SEPARATELY.

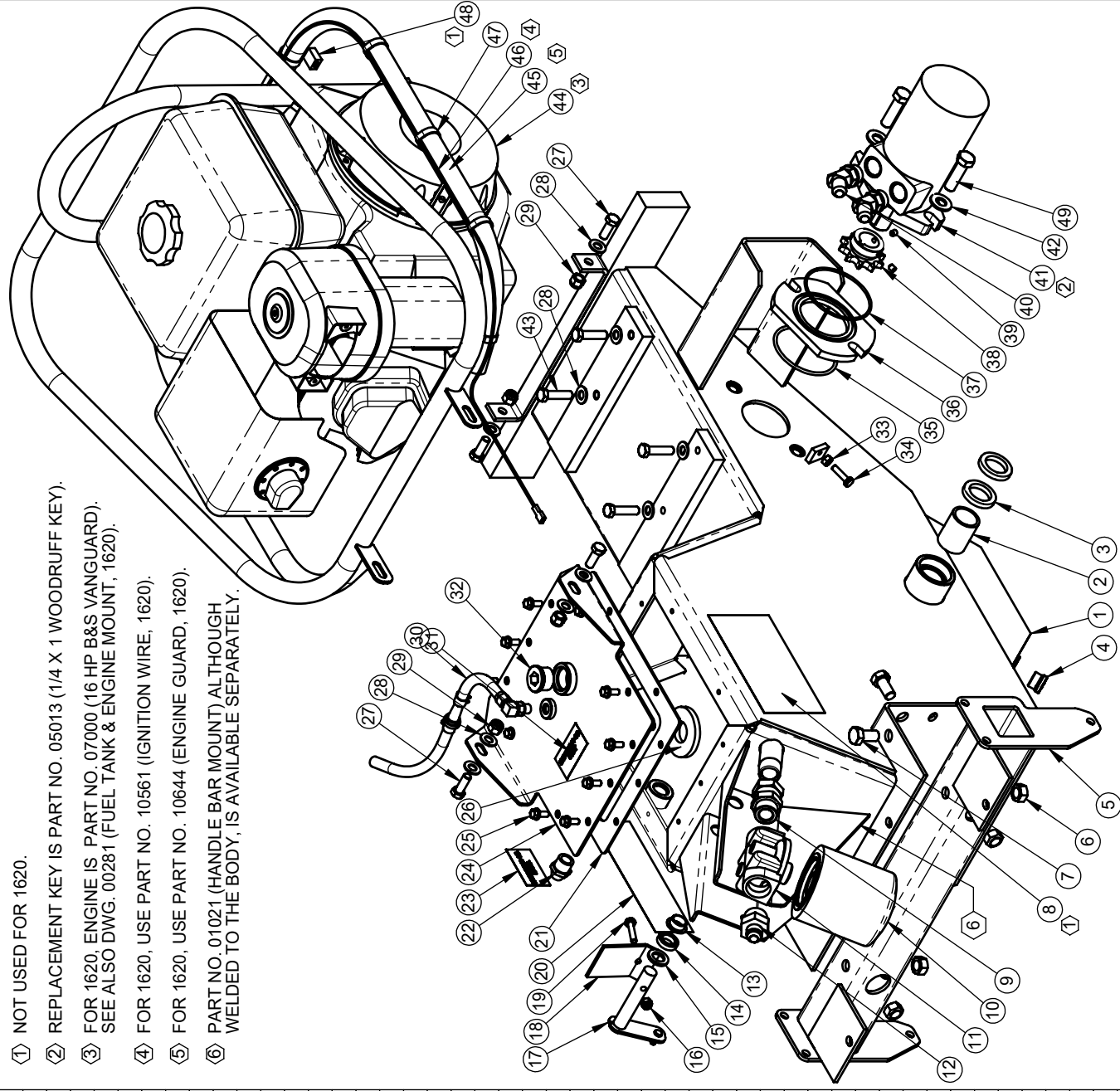

TITLE: BODY

BARRETO

PRODUCT LINE: 1320 & 1620 DATE: 4/02/2018

SCALE: 1:7.5

SHEET 1 OF 1

DWG# 00279 R5

ITEM NO.	QTY.	PART NO.	DESCRIPTION
1	1	00281	1620 ENGINE ASSEMBLY
2	1	04517 R1	BREATHER HOSE ASSEMBLY
3	1	10532	BODY
4	1	10644	ENGINE GUARD, 1620
5	1	10536	TORQUE TUBE, 21"
6	1	10122	LID
7	1	01038	ACTUATOR ARM
8	1	01037	ACTUATOR PLATE
9	1	02004	WHEEL MOTOR SPACER
10	1	04003-F	WHEEL DRIVE MOTOR WITH KEY
11	1	02014	SPROCKET, #50, 10 TOOTH
12	1	03000	O-RING, 2-234, 3-1/4 OD X 1/8 SECTION
13	1	03001	O-RING, 2-152, 3-7/16 OD X 3/32 SECTION
14	1	03040-06	DECAL, "HYDRAULIC OIL ONLY"
15	2	03040-09	DECAL, "1620"
16	1	03040-15	DECAL, SERIAL NUMBER
17	1	03040-57	DECAL, "HYDRAULIC OIL LEVEL"
18	2	03007	BUSHING, AXLE
19	4	03012	SEAL, AXLE
20	1	03951	FILTER, HYDRAULIC OIL, WITH BY-PASS
21	1	04403	FILTER HEAD, #12 O-RING
22	1	10808	FITTING, 6400-8-12
23	1	04221	FITTING, 6900-12-12
24	1	10361	FITTING, 6409-8 PLUG
25	2	04557	FITTING, 6802-8-10
26	2	03060	BUSHING, IGUS MFI-1012-06
27	1	03020	SEAL
28	1	03061	FELT WASHER, 5/8 X 1 X 1/8
29	1	03041	GASKET, TILLER LID
30	1	03503	SIGHT GAUGE
31	1	03520	MAGNET
32	1	10526	FITTING, 6409-12 PLUG
33	1	06422	IGNITION WIRE, 81"
34	7	03035	TIE WRAP, 1/8 X 6
35	1	03806	QUICK-SPLICE
36	4	05067	HH CAP SCREW, 1/2-13 NC X 1 G5 ZINC
37	2	05102	WASHER, 1/2 SAE ZINC HARDENED
38	4	05046	NUT, GRIPCO, 1/2-13 NC G5 ZINC
39	2	05098	NUT, NYLOCK, 1/2-13 NC ZINC
40	4	05059	HH CAP SCREW, 3/8-16 NC X 1 G5 ZINC
41	8	05101	WASHER, 3/8 SAE ZINC
42	4	05073	NUT, NYLOCK, 3/8-16 NC ZINC
43	2	05021	SET SCREW, 1/4-20 UNC X 5/16, CUP POINT
44	1	05125	HH CAP SCREW, 1/4-20 NC X 1-1/4 G5 ZINC
45	1	05237	HH CAP SCREW, 1/4-20 NC X 1 G5 ZINC
46	10	05069	WHIZ-LOCK 1/4 - 20 X 5/8
47	1	05090	NUT, 1/4-20 NC ZINC
48	1	05096	NUT, NYLOCK, 1/4-20 NC ZINC

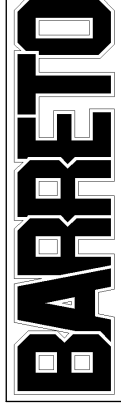
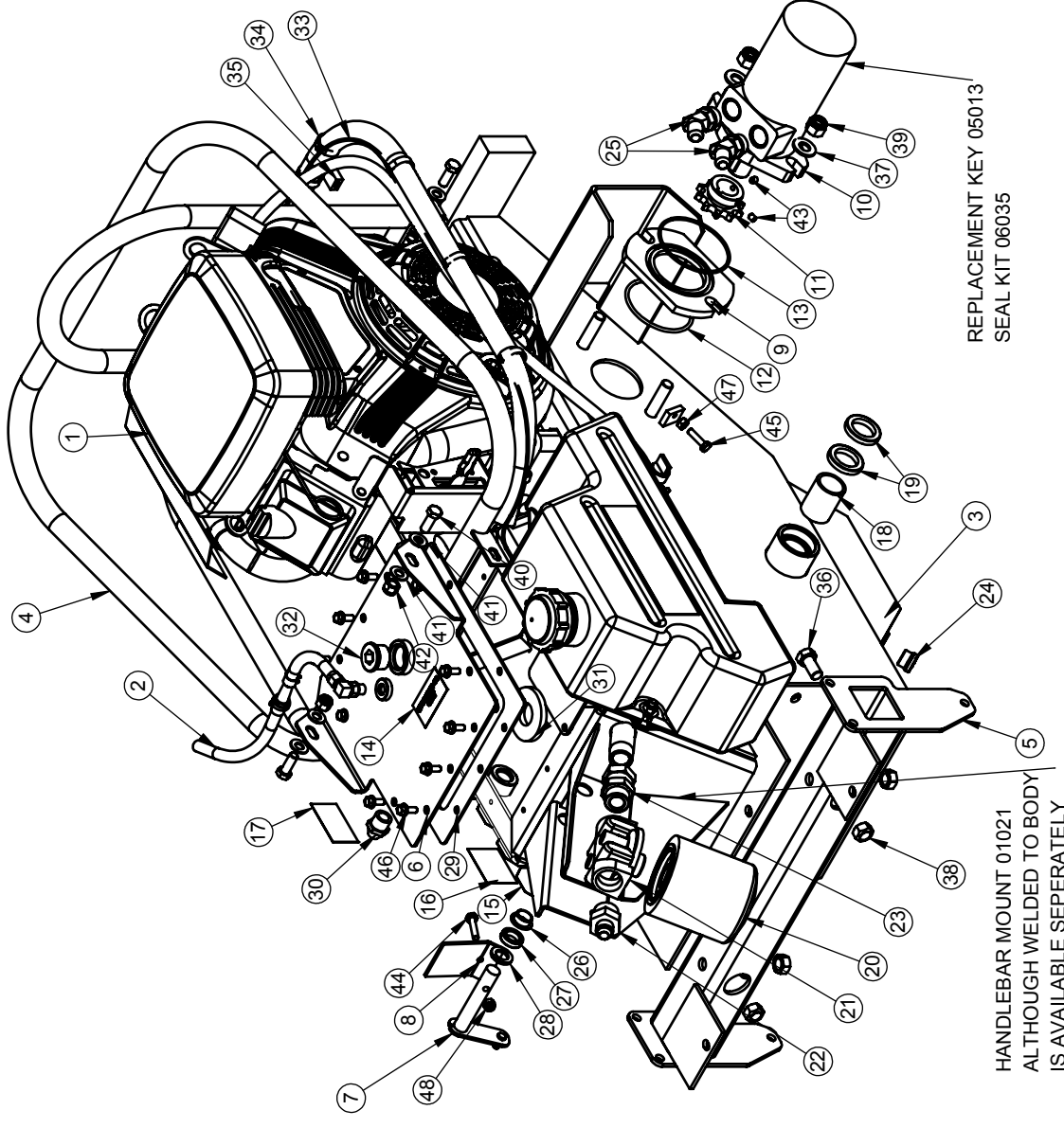

TITLE: BODY ASSEMBLY

PRODUCT LINE: 1620

SCALE: 1:8

SHEET 2 OF 2

DWG# 00279 R5

UPDATE 11/23/16

ITEM NO.	QTY.	PART NO.	DESCRIPTION
1	1	104010	CONTROL VALVE BODY (ORDER 04010-K)
2	4	05200	ROLL PIN (SLOTTED SPRING), 1/4 X 1-1/4 ZINC
3	1	106421	GROUND WIRE, IGNITION SWITCH
4	2	05273	NUT, NYLOCK, 5/16-18 NC ZINC
5	2	03027	DETENT SPRING
6	2	02017	HANDLE, 5/16 X 7
7	1	104015-D	VALVE SPOOL, TINES (ORDER 04010-K)
8	4	03002	O-RING, 2-210, 1" OD X 1/8 SECTION
9	4	03025	BACK-UP RING, 1" TEFLON
10	4	05010	SNAP RING, 1" EXTERNAL
11	2	05573	SH CAP SCREW, 1/4-20 NC X 3/8 ZINC
12	2	04554	FITTING, 6801-8-8
13	2	03026	KNOB, 5/16-NC
14	1	103040	DECAL, CONTROL VALVE
15	4	04520	FITTING, 6400-8-8
16	1	105023	PIPE PLUG, 1/8"
17	4	03300	FITTING, 6409-4 PLUG
18	2	05065	HH CAP SCREW, 5/16-18 NC X 2-3/4 G5 ZINC
19	1	104015-C	VALVE SPOOL, WHEEL DRIVE (ORDER 04010-K)
20	1	104308	HOSE, CONTROL VALVE TO ACTUATOR TEE FITTING
21	1	104310 R1	HOSE, CONTROL VALVE TO TINE MOTOR REAR PORT
22	1	104310 R1	HOSE, CONTROL VALVE TO TINE MOTOR FRONT PORT
23	1	104311	HOSE, CONTROL VALVE TO WHEEL MOTOR LOWER PORT
24	1	104311	HOSE, CONTROL VALVE TO WHEEL MOTOR UPPER PORT
25	1	104313	HOSE, CONTROL VALVE TO OIL FILTER MOUNT

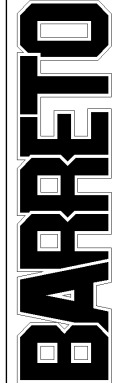
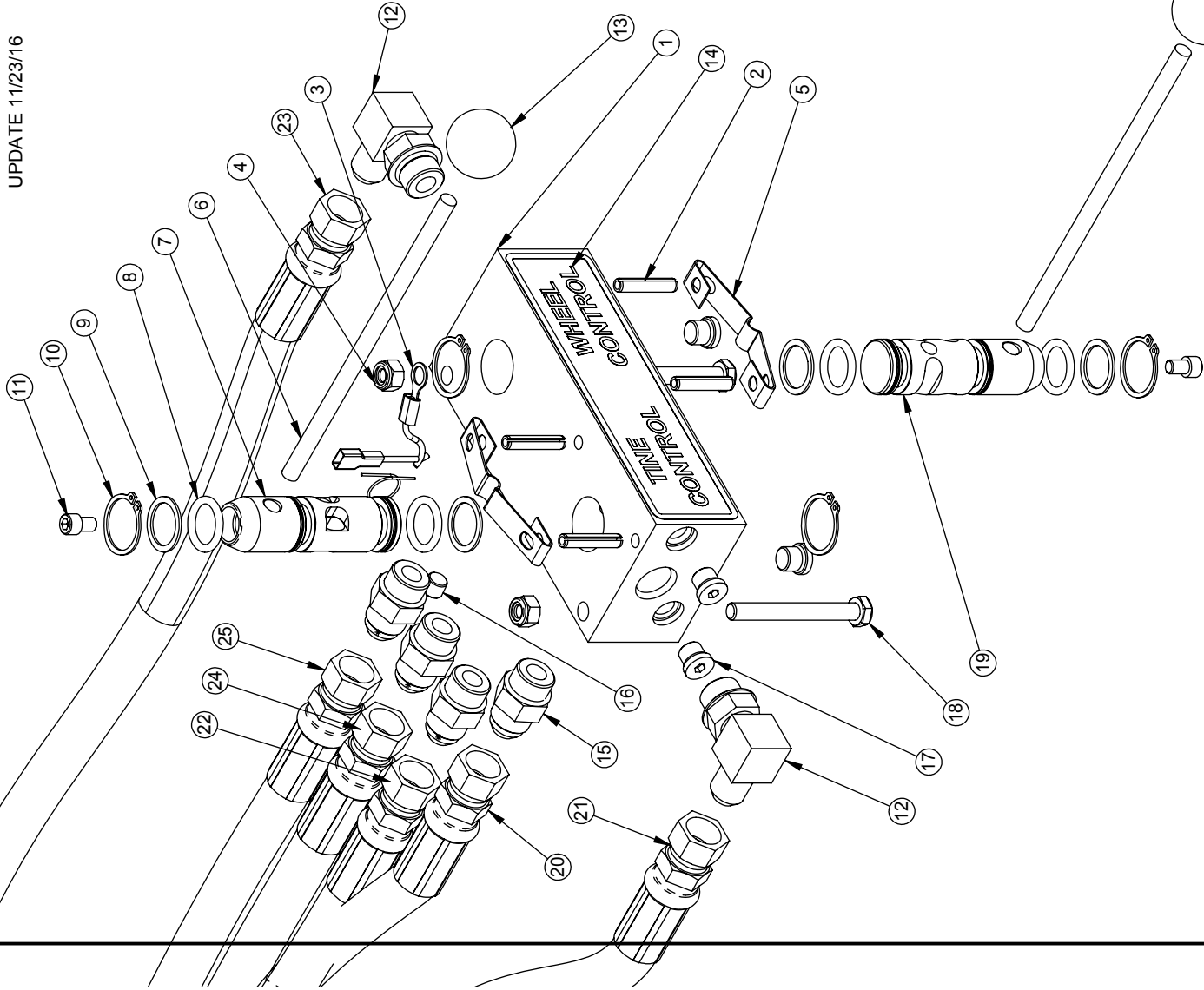

TITLE: CONTROL VALVE
 PRODUCT LINE: 1320 & 1620 DATE: 4/26/07
 SCALE: 1:3 DWG# 00280 R2
 SHEET 1 OF 1

REF	QTY.	PART NO.	DESCRIPTION
1	1	07000	ENGINE, B&S VANGUARD 16HP
2	1	01013	MOUNTING PLATE, 16 HP B&S ENGINE
3	2	01014	SPACER, ENGINE
4	1	10556	MOUNTING BRACKET, FUEL TANK
5	1	01040	HEAT SHIELD, 16 HP B&S ENGINE
6	1	10559	FUEL TANK, 1620, INCLUDES KELCH CAP
7	1	03062-12	FUEL TANK CAP, KELCH
8	1	10559-1	FITTING, 1/4 NPT TO 1/4 HOSE BIB, STRAIGHT
9	4	03062-06	CLAMP, 1/4" FUEL LINE
10	1	11346	HOSE, 1/4" GASOLINE, 4L5, 11" LONG
11	1	03062-03	FUEL SHUT OFF VALVE
12	1	11352	HOSE, 1/4" GASOLINE, 4L5, 24 LONG
13	1	07000-01	MUFFLER, B&S 16HP VANGUARD
14	1	07000-02	CLAMP, MUFFLER, WITH CARRIAGE BOLT & NUT
15	1	07000-03	MOUNTING BRACKET, MUFFLER
16	1	07000-04	MANIFOLD WITH GASKETS & FASTENERS
17	2	03070	SCREW, 6MM
18	2	03071	SCREW, 8MM
19	2	05041	HOSE CLAMP, 1" SS
20	4	05057	HH CAP SCREW, 3/8-16 NC X 3/4 G5 ZINC
21	4	05101	WASHER, 3/8 SAE ZINC
22	2	05297	HH CAP SCREW, 5/16-18 NC X 1-1-4 G5 ZINC
23	1	05140	WHIZ-LOCK 5/16 - 18 X 3/4
24	8	05068	WASHER, 5/16 SAE ZINC
25	6	05273	NUT, NYLOCK, 5/16-18 NC ZINC

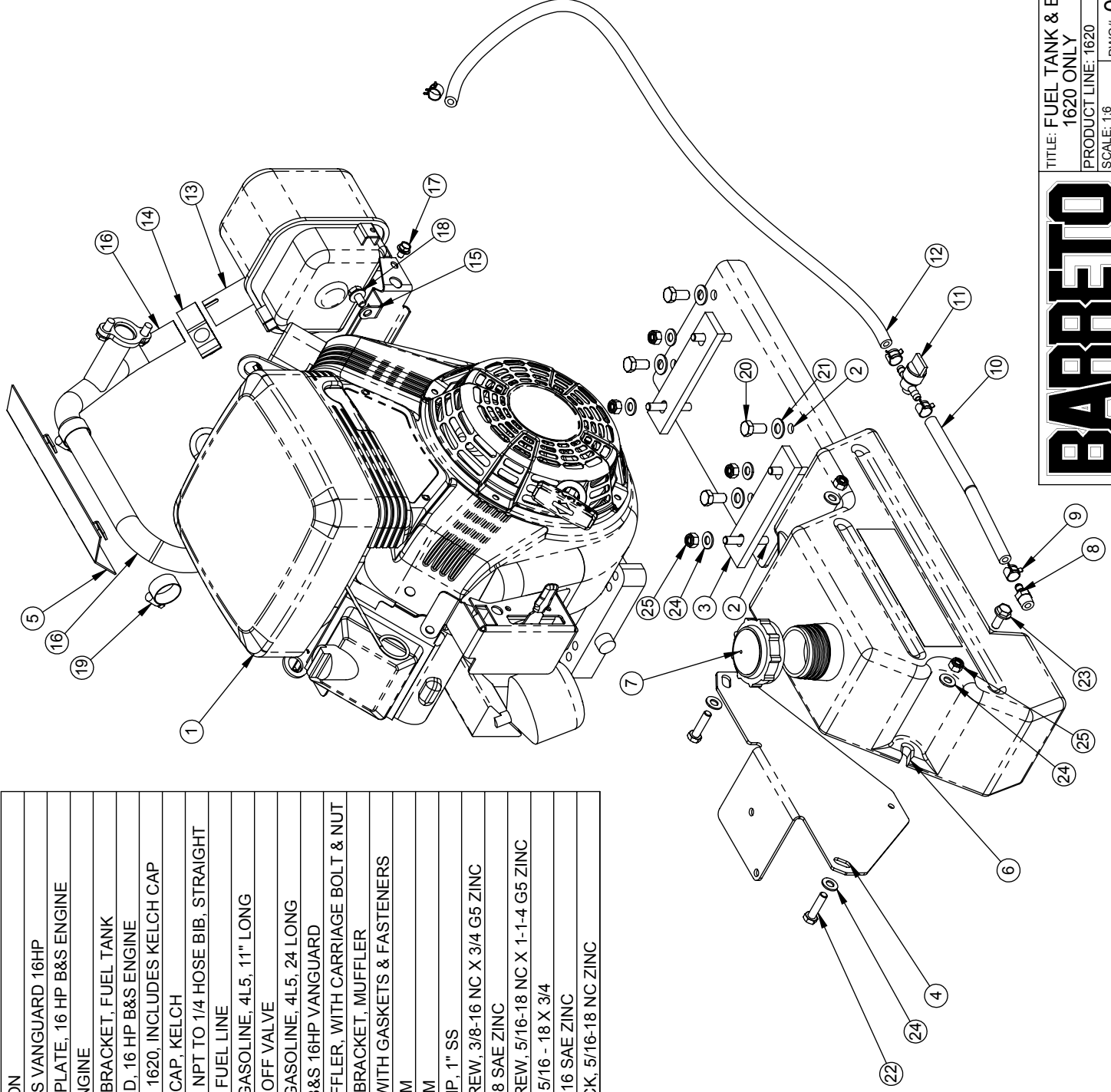

BARRETO

TITLE: FUEL TANK & ENGINE MOUNT,
1620 ONLY

PRODUCT LINE: 1620 DATE: 4/26/07

SCALE: 1:8 SHEET 1 OF 1 DWG# 00281

REF QTY.	PART NO.	DESCRIPTION	REF QTY.	PART NO.	DESCRIPTION
1	01017	HANDLE BARS	14	03029	LEVER ASSEMBLY (COMPLETE)
2	02027-L	HANDLE BAR ADJUSTER PIN, LOWER	15	03045	CABLE, ACTUATOR
3	05216	SNAP RING, 3/4 EXTERNAL	16	05081	WASHER, 1/4 SAE ZINC
4	03501	BUSHING, IGUS MFI-0810-08	17	05039	CIRCLE COTTER CC-3
5	05102	WASHER, 1/2 SAE ZINC HARDENED	18	03341-07	DECAL, "IGNITION OFF/ON"
6	05093	HH CAP SCREW, 1/2-13 NC X 3 G5 ZINC	19	06420	ROCKER SWITCH, IGNITION OFF/ON
7	05098	NUT, NYLOCK, 1/2-13 NC ZINC	20	10667	HOSE KEEPER
8	01030	CRANK, HANDLE BAR ADJUSTMENT	21	10668	SPACER, HOSE KEEPER
9	05058	WASHER, 3/8 NYLON	22	05065	HH CAP SCREW, 5/16-18 NC X 2-3/4 G5 ZINC
10	05103	WASHER, 3/8 A325 HARDENED ZINC	23	05068	WASHER, 5/16 SAE ZINC
11	02027-U	PIN, HANDLE BAR ADJUSTMENT, UPPER	24	05273	NUT, NYLOCK, 5/16-18 NC ZINC
12	05269	NUT, 3/8-16 NC GRB ZINC	25	03009-R2	HOURLY METER W/OUT FLASH ALERT
13	03032-01	GRIP, 1 X 5 (P/N 03032 IS A PAIR)			

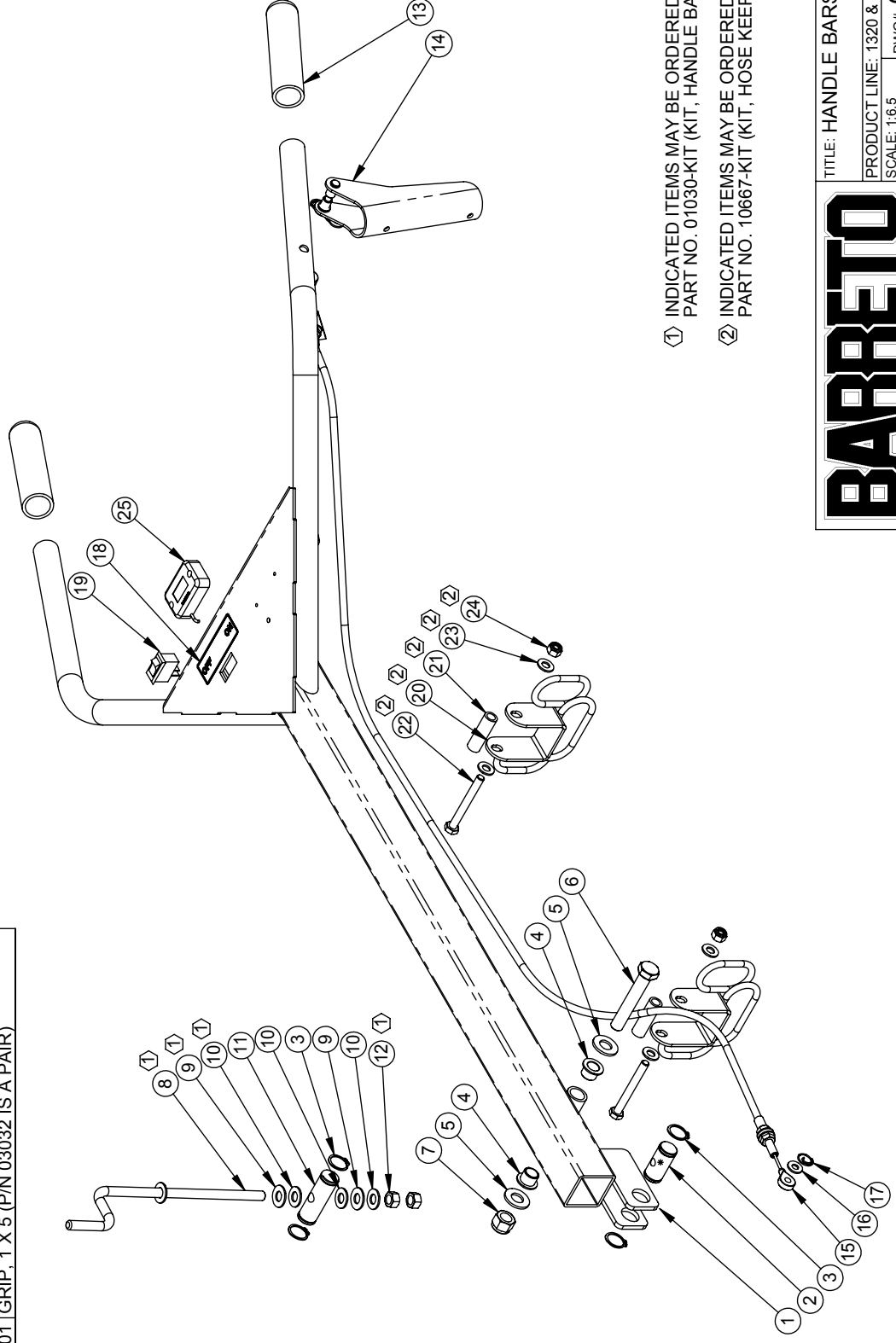

- ① INDICATED ITEMS MAY BE ORDERED AS A KIT.
PART NO. 01030-KIT (KIT, HANDLE BAR ADJUSTMENT).
- ② INDICATED ITEMS MAY BE ORDERED AS A KIT.
PART NO. 10667-KIT (KIT, HOSE KEEPER W/FASTENERS).

BARRETO

TITLE: HANDLE BARS & CRANK

PRODUCT LINE: 1320 & 1620
SCALE: 1:6.5
SHEET 1 OF 1

1/16/07

DWG# 00282 R1

UPDATE 11/23/16

REF	QTY.	PART NO.	DESCRIPTION
1	1	02016	PUMP ADAPTER
2	1	04004-A	PUMP, HYDRAULIC
3	1	03021	JAW COUPLER, PUMP, 5/8" BORE
4	1	03022	SPIDER, RUBBER
5	1	03023	JAW COUPLER, 1" BORE L095
6	1	05014-A	KEY, 1/4 X 1/4 X 5/8
7	1	04211	FITTING, 6801-8-10
8	1	04306	HOSE, PUMP TO TEE, 1320
9	1	04017	FITTING, 6803-8-8-8
10	2	04202	FITTING, 4601-12-12
11	2	05008	CLAMP, 3/4" HOSE, CTB-29
12	1	04302	HOSE, INTAKE, 1320
13	1	10247	SUMP SCREEN #20 EXT #12 INT O-RING
14	1	03293	O-RING, 3-920N90, -20 FITTINGS
15	6	05091	HH CAP SCREW, 3/8-16 NC X 1-1/4 G5 ZINC
16	6	05101	WASHER, 3/8 SAE ZINC

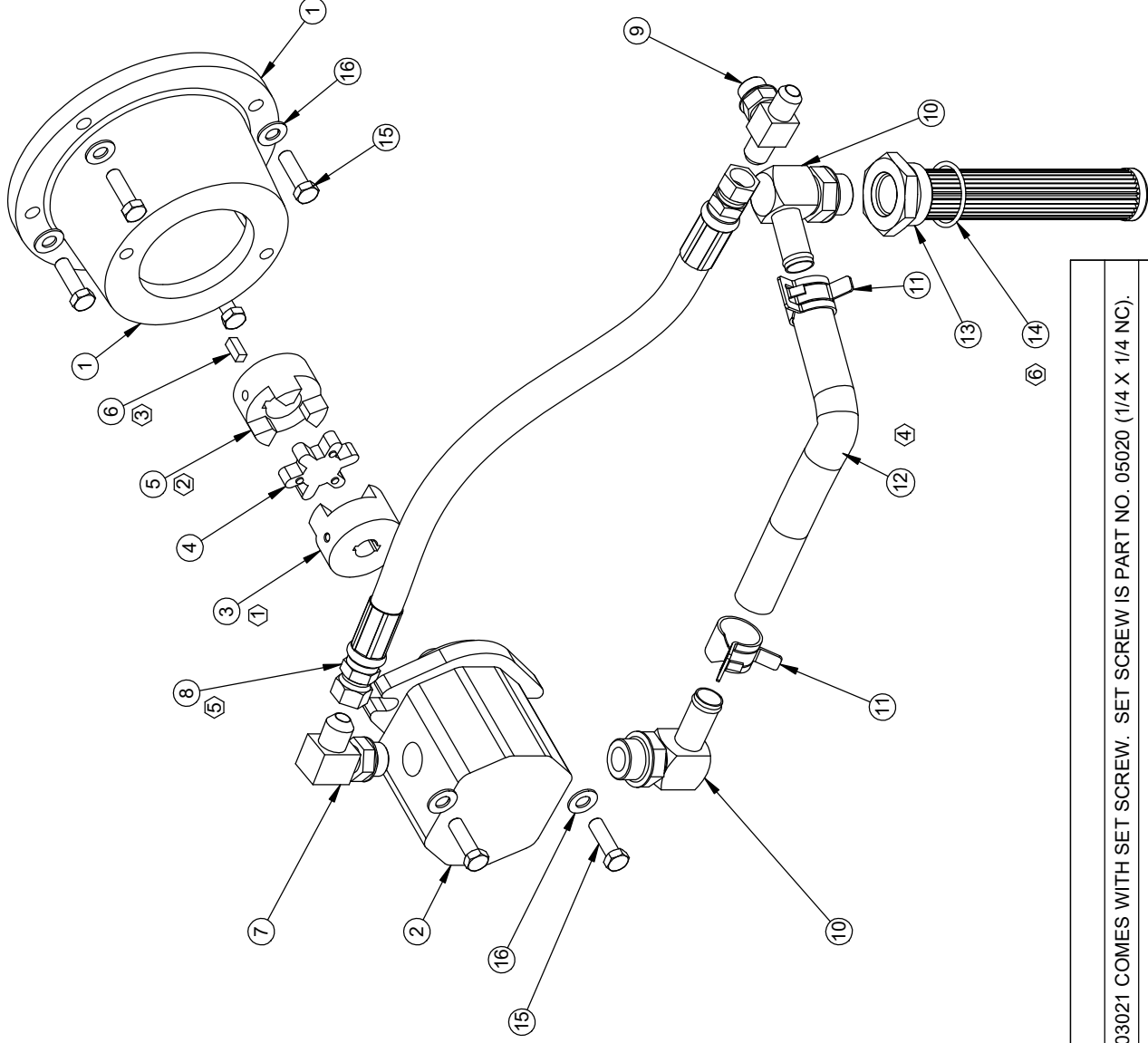

NOTES:

- 03021 COMES WITH SET SCREW. SET SCREW IS PART NO. 05020 (1/4 X 1/4 NC).
- 03023 COMES WITH SET SCREW. SET SCREW IS PART NO. 05127 (5/16 X 5/16 NC).
- FOR 1620, USE PART NO. 05014 (1/4 X 1/4 X 3/4 KEY).
- FOR 1620, USE PART NO. 04301 (HOSE, INTAKE, 1620).
- FOR 1620, USE PART NO. 04305 (HOSE, PUMP TO TEE, 1620).
- O-RING 03293 COMES WITH SUMP SCREEN 10247

BARRETO

TITLE: PUMP ASSEMBLY

PRODUCT LINE: 1320 & 1620 DATE: 9/5/07

SCALE: 1:4.5

SHEET 1 OF 2 DWG# 00283 R1

ITEM NO.	QTY.	PART NO.	DESCRIPTION
48	2	05073	NUT, NYLOCK, 3/8-16 NC ZINC
49	12	05140	WHIZ-LOCK 5/16 - 18 X 3/4
50	12	05273	NUT, NYLOCK, 5/16-18 NC ZINC

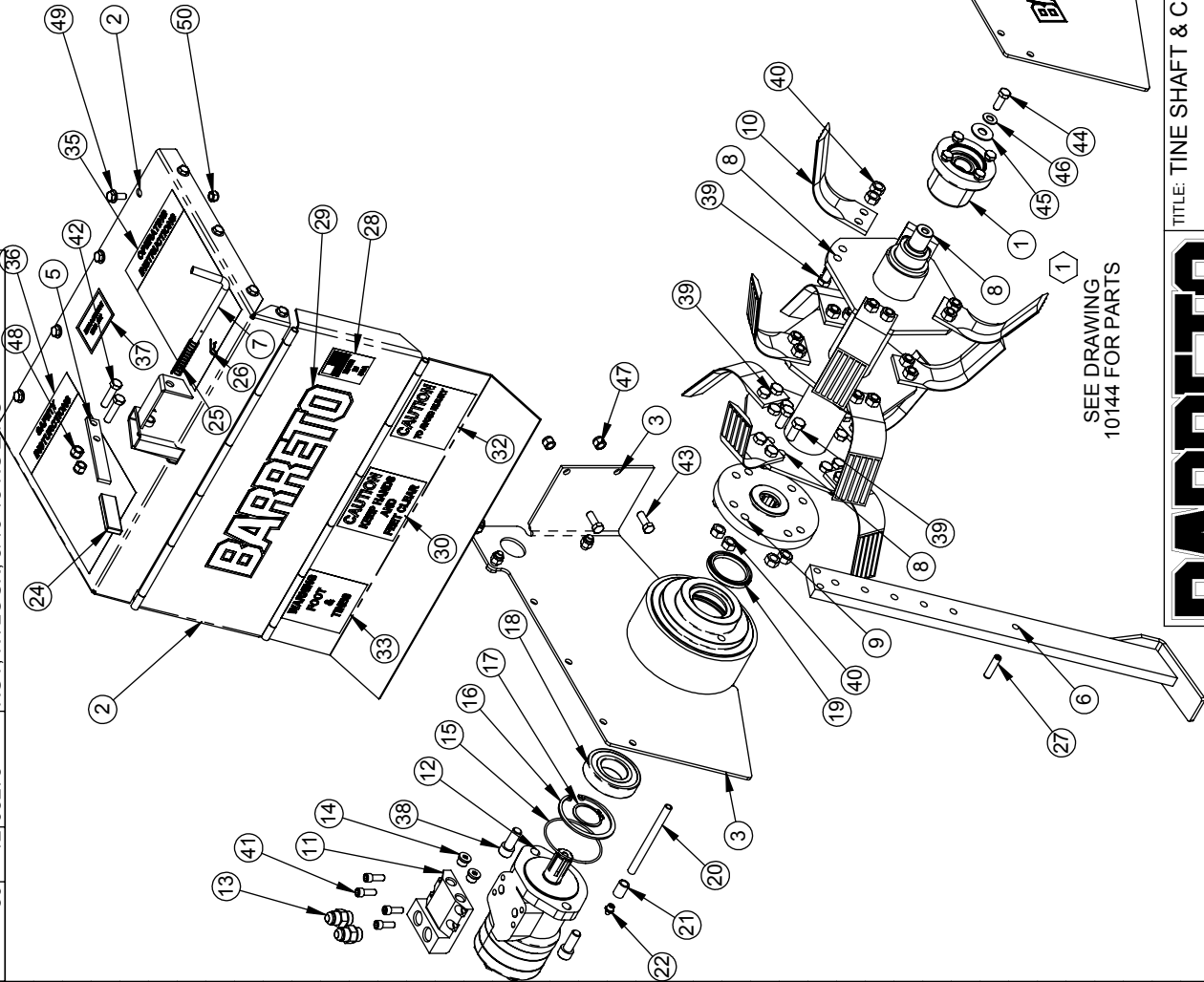

ITEM NO.	QTY.	PART NO.	DESCRIPTION
1	1	10144	OUTBOARD BEARING ASSEMBLY (1)
2	1	101008	TINE COVER, 1320/1620
3	1	12424	TINE SIDE PLATE, LEFT
4	1	10538	RH SIDE PLATE, TINE SECTION
5	1	101099	HANDLE, DEPTH BAR
6	1	101012	DEPTH BAR
7	1	101018	PIN
8	1	12423	TINE SHAFT, SPLINED
9	1	11278	TINE MOTOR HUB, SPLINED
10	12	03196 R1	TINE, REVERSIBLE (SET OF 12: 03196 R1-12)
11	1	102065	MANIFOLD, TINE MOTOR
12	1	104605-F	TINE MOTOR
13	2	04520	FITTING, 6400-8-8
14	2	03302	FITTING, 6409-6 PLUG
15	1	03001	O-RING, 2-152, 3-7/16 OD X 3/32 SECTION
16	1	05603	SNAP RING, HO-315, 3-5/32 INTERNAL
17	1	05607	SNAP RING, SH-156, 1-9/16" EXTERNAL
18	1	103943	BALL BEARING, SKF 6208
19	1	103930	SEAL, CR 19763
20	1	05282	PIPE NIPPLE, 1/8" X 5 LONG
21	1	05204	PIPE COUPLER, 1/8"
22	1	05256	GREASE ZERK, 1/8 NPT
23	1	05044	GREASE ZERK, 1/4-28 UNF
24	1	03018	GRIP, 1/8 X 3/4 X 2-3/4
25	1	03080	SPRING
26	1	03065	HAIR SPRING COTTER #4
27	1	05006	ROLL PIN (SLOTTED SPRING), 3/8 X 1-1/2 ZINC
28	1	03040-01	DECAL, "MADE IN USA"
29	1	03040-02	DECAL, "BARRETO", 3-1/2 X 11-1/4
30	1	03040-03	DECAL, "CAUTION" (BLACK & WHITE)
31	1	03040-04	DECAL, "GREASE DAILY"
32	1	03040-07	DECAL, "CAUTION" (YELLOW)
33	1	03040-08	DECAL, "WARNING" (YELLOW)
34	2	03040-11	DECAL, "BARRETO", 2-3/16 X 7-3/8
35	1	03341-22	DECAL, "TILLER OPERATING INSTRUCTIONS"
36	1	03341-23	DECAL, "TILLER SAFETY INSTRUCTIONS"
37	1	03040-59	DECAL "REPLACEMENT TINE PN"
38	2	05585	SH CAP SCREW, 1/2-13 NC X 1-1/4 ZINC
39	32	05061	HH CAP SCREW, 7/16-20 NF X 1 G8 ZINC
40	32	05074	NUT, 7/16-20 NF G8 ZINC
41	4	05361	SH CAP SCREW, 5/16-18 NC X 7/8 ZINC
42	2	05092	HH CAP SCREW, 3/8-16 NC X 1-1/2 G5 ZINC
43	10	05056	HH CAP SCREW, 3/8-24 NF X 1 G5 ZINC
44	1	05059	HH CAP SCREW, 3/8-16 NC X 1 G5 ZINC
45	1	05083	WASHER, 7/16 USS ZINC
46	1	05103	WASHER, 3/8 A325 HARDENED ZINC
47	10	05072	NUT, NYLOCK, 3/8-24 NF ZINC

SEE DRAWING
10144 FOR PARTS

BARRETO

TITLE: TINE SHAFT & COVER ASSEMBLY

PRODUCT LINE: 1320 / 1620 DATE: 9-12
SCALE: 1:10 DWG# 00284-SPL
SHEET 1 OF 1

REF. QTY.	PART NO.	DESCRIPTION
1	04555	FITTING, 6801-4-4
2	04214	FITTING, JS-4-4, HOSE BARB 1/4 X 1/4 SWIVEL
3	11350	HOSE, 1/4 INCH GASOLINE, 4L5, 5" LONG
4	03062-06	CLAMP, 1/4" FUEL LINE
5	04516	BREATHER, FILTER SNAPPER 1435
6	11351	HOSE, 1/4 INCH GASOLINE, 4L5, 8" LONG

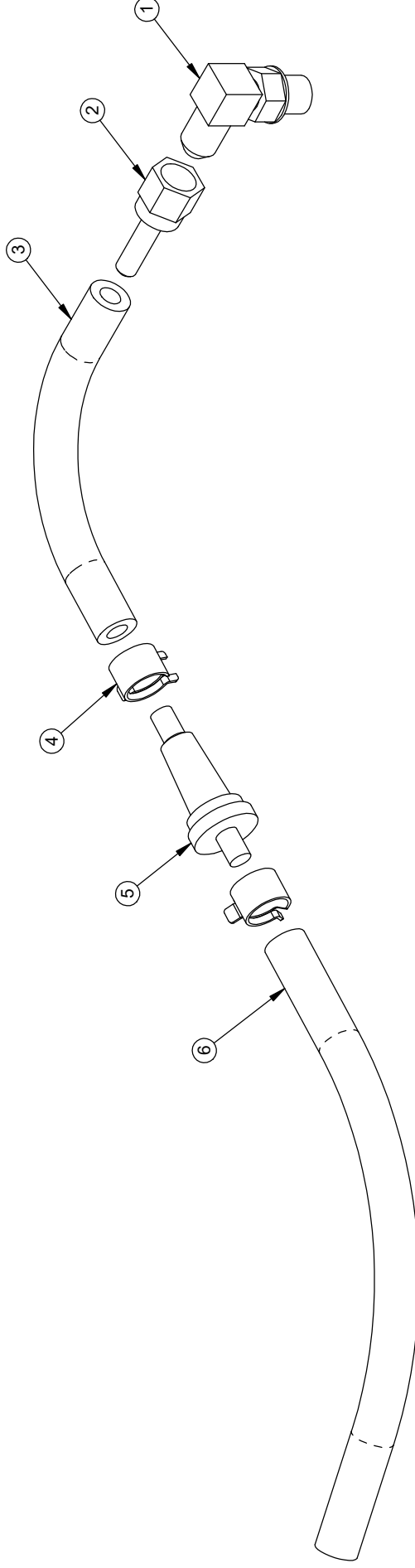

NOTES:

1. USAGE: 1 PER 1320 & 1620

BARRETO

TITLE: BREATHER HOSE ASSEMBLY

PRODUCT LINE: 1320 & 1620 DATE: 4/26/07

SCALE: 1:1.8

SHEET 1 OF 1

DWG# 04517 R1

REF QTY.	PART NO.	DESCRIPTION
1	2	02269-HUB WHEEL HUB ASSY, 1-1/8" BORE
2	1	03046 TIRE & RIM, TILLER LH, TRENCHER RH, 16 X 6.50 -8
3	1	03047 TIRE & RIM, TILLER RH, TRENCHER LH, 16 X 6.50 -8
4	4	02083 SPACER, WHEEL
5	2	01077 MOUNTING PLATE, PIN, FREE WHEELING
6	2	02068 PIN, FREE WHEELING
7	4	05548 ROLL PIN (SLOTTED SPRING), 1/8 X 3/4 ZINC
8	2	05102 WASHER, 1/2 SAE ZINC HARDENED
9	2	03352 SPRING, CENTURY 3385
10	2	03550 SPLIT RING-27
11	6	05042 NUT, LUG, 1/2-20 NF

① REFERENCE DWG# 02269-HUB FOR INDIVIDUAL PARTS.

② RIM ALONE IS PART NO. 03049, TIRE ALONE IS PART NO. 03048. CALL REGARDING OPTIONAL FOAM FILLED TIRES.

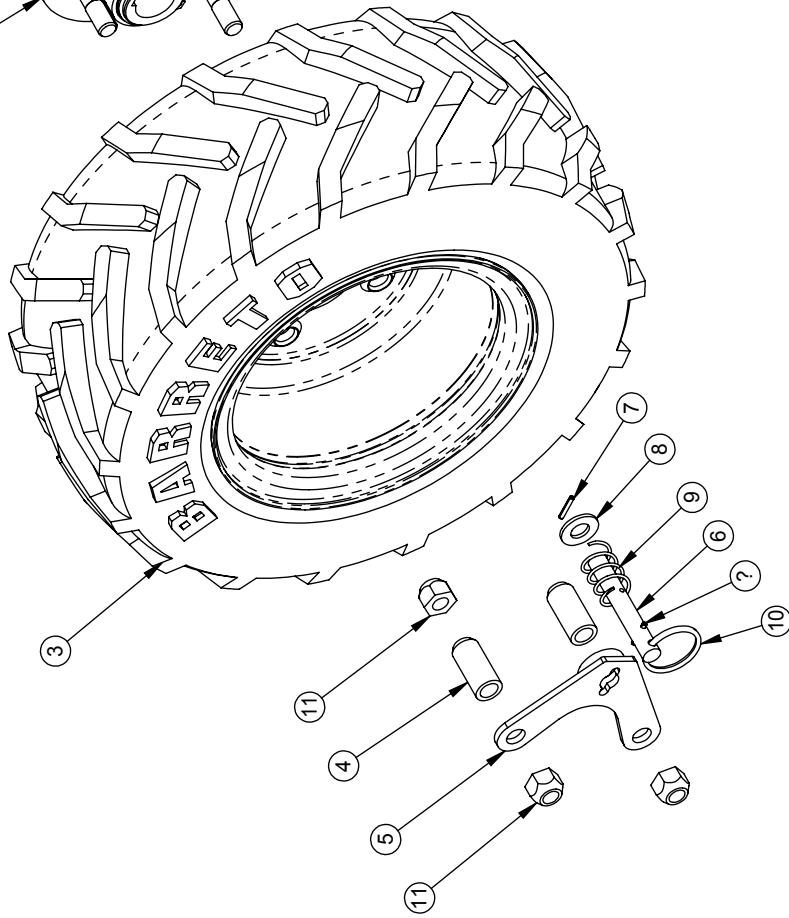
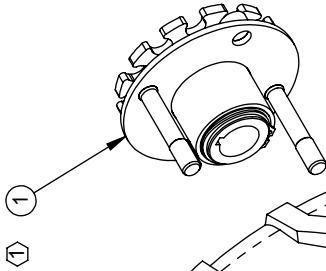
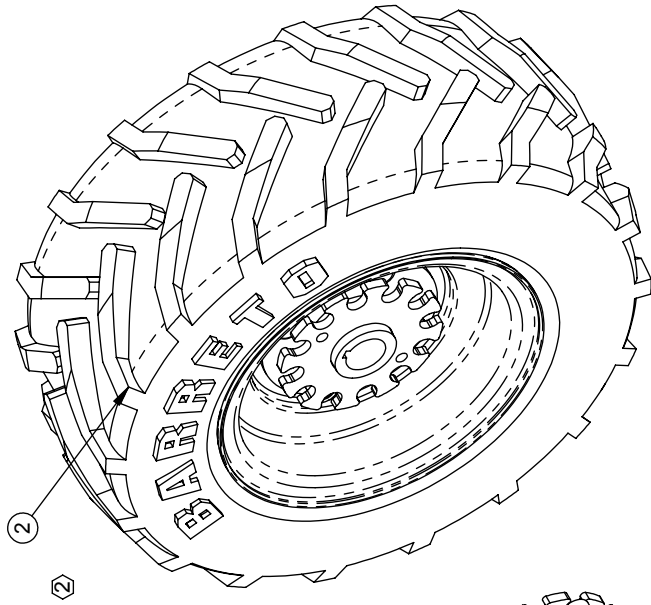

ASSEMBLED VIEW

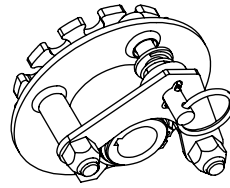

BARRETO

TITLE: FREE WHEEL HUBS & WHEELS

PRODUCT LINE: 1320 & 1620

DATE: 8/9/07

SCALE: 1:5

SHEET 1 OF 1

DWG# 10388

REF. QTY.	PART NO.	DESCRIPTION
1	02269	WHEEL HUB
2	01252	FREE WHEEL HUB
3	03168	BUSHING, SLEEVE, NYLON, IGUS MSI-2832-12
4	05610	SNAP RING, SH-175, 1-3/4" EXTERNAL
5	05066	KNURLED STUD, 1/2-20 UNF X 1, G8
6	05166	KNURLED STUD, 1/2-20 UNF X 3, G8

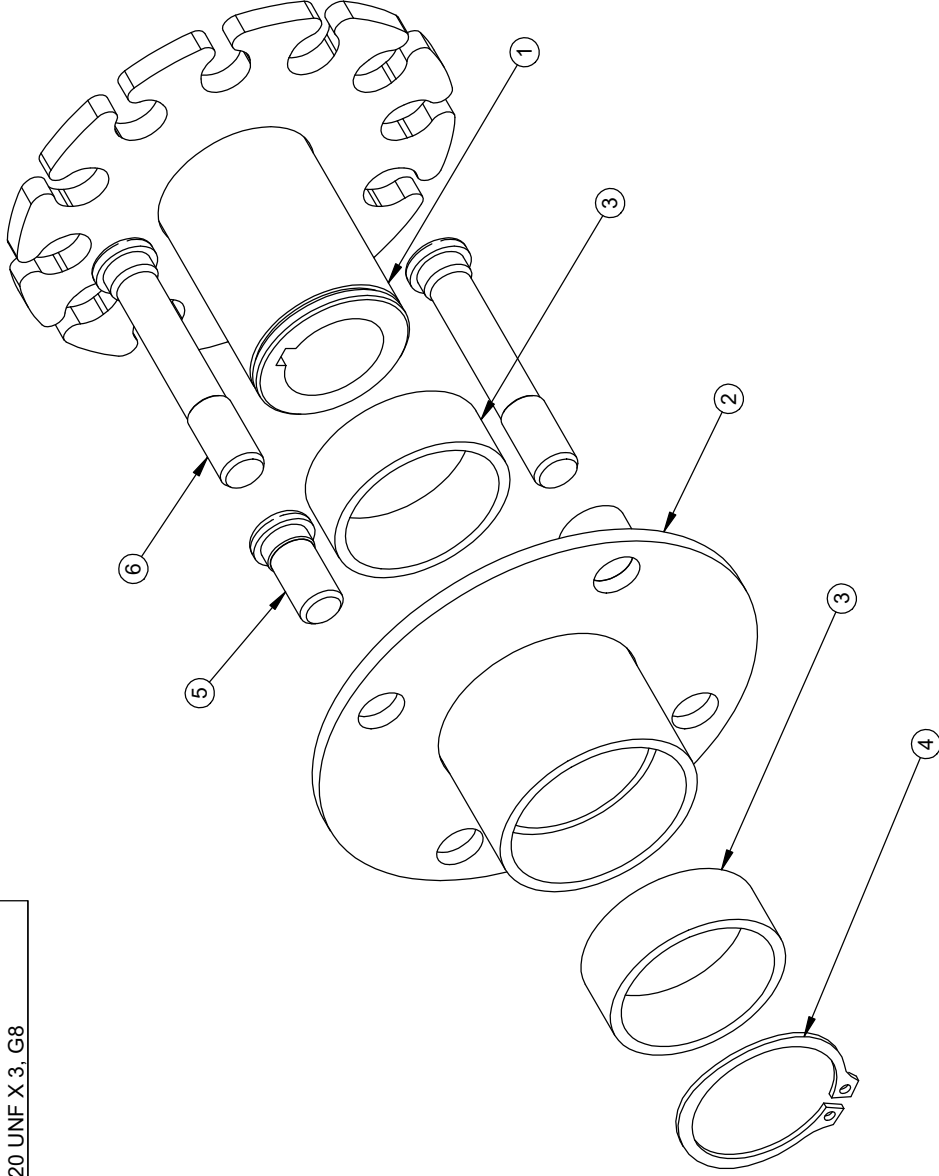

NOTES:

- 1. USAGE: 2 PER 00231 R3, 00256 R1, & 10388.
- 1 OF 00231 R3 PER 1318.
- 1 OF 00256 R1 PER 912, 916 & 918.
- 1 OF 10388 PER 1320 & 1620.

BARRETO

TITLE: WHEEL HUB ASSY, 1-1/8" BORE

PRODUCT LINE: COMMON DATE: 8/6/07

SCALE: 1:2 DWG# 02269-HUB

SHEET 1 OF 1

REF QTY.	PART NO.	DESCRIPTION
1	10142	OUTBOARD BEARING HOUSING, 4 BOLT
2	01039	SHIELD, ROLLER BEARING
3	03043	BALL BEARING, 6205
4	05024	SNAP RING, HO-200, 2" INTERNAL
5	03904	O-RING, 2-035, 2-3/8 OD X 1/16 SECTION
6	05059	HH CAP SCREW, 3/8-16 NC X 1 G5 ZINC

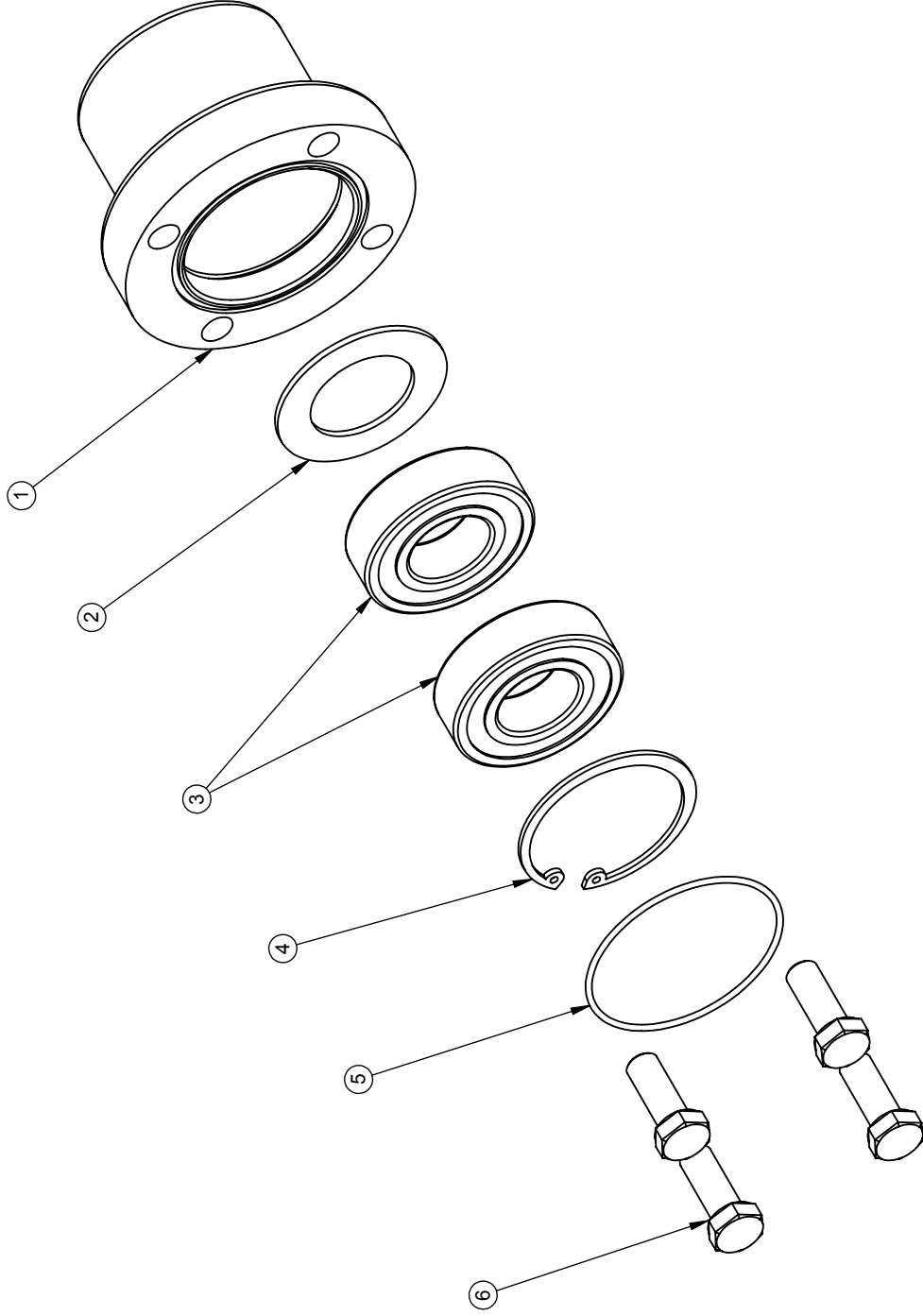

BARRETO

TITLE: OUTBOARD BEARING ASSEMBLY,
4 BOLT

PRODUCT LINE: COMMON DATE: 3/2/04

SCALE: 1:2 SHEET 1 OF 1 DWG# 10144

ITEM NO.	QTY.	PART NO.	DESCRIPTION
1	1	12102-R	LIFT MOUNT, RT
2	1	12102-L	LIFT MOUNT, LEFT
3	1	12101	LIFT LOOP
4	4	05101	WASHER, 3/8 SAE ZINC
5	4	05056	HH CAP SCREW, 3/8-24 NF X 1 G5 ZINC
6	4	05072	NUT, NYLOCK, 3/8-24 NF ZINC
7	8	05535	WHIZ-LOCK 1/4 - 20 X 7/8

UPDATE 12/6/16

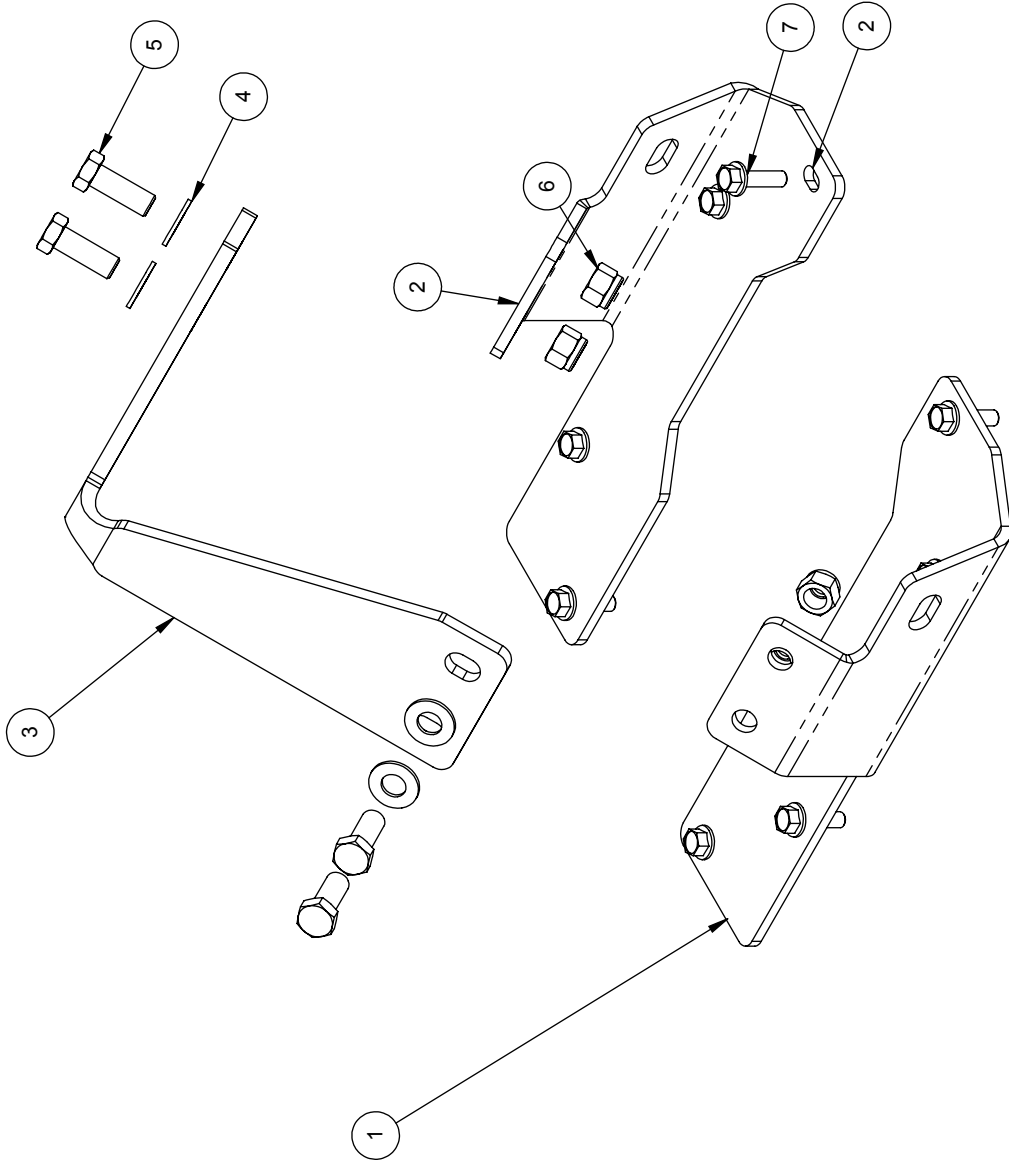

BARRETO

TITLE: LIFT EYE, BOLT-ON

PRODUCT LINE: 1320 / 1620 DATE: 06-14

SCALE: 1:3 SHEET 1 OF 1 DWG# A1555

ITEM NO.	QTY.	PART NO.	DESCRIPTION
1	1	00279 R5	BODY ASSEMBLY
2	1	00284-SPL	TINE SHAFT & COVER ASSEMBLY
3	1	00282 R1	HANDLE BARS
4	1	00280 R2	CONTROL VALVE
5	1	00277	ACTUATOR VALVE
6	1	00283 R1	PUMP ASSEMBLY
7	1	00278 R1	AXLE
8	1	10388	FREE WHEELING HUBS & WHEELS
9	1	A1555	LIFT EYE, BOLT-ON, OPTIONAL

1320 SHOWN

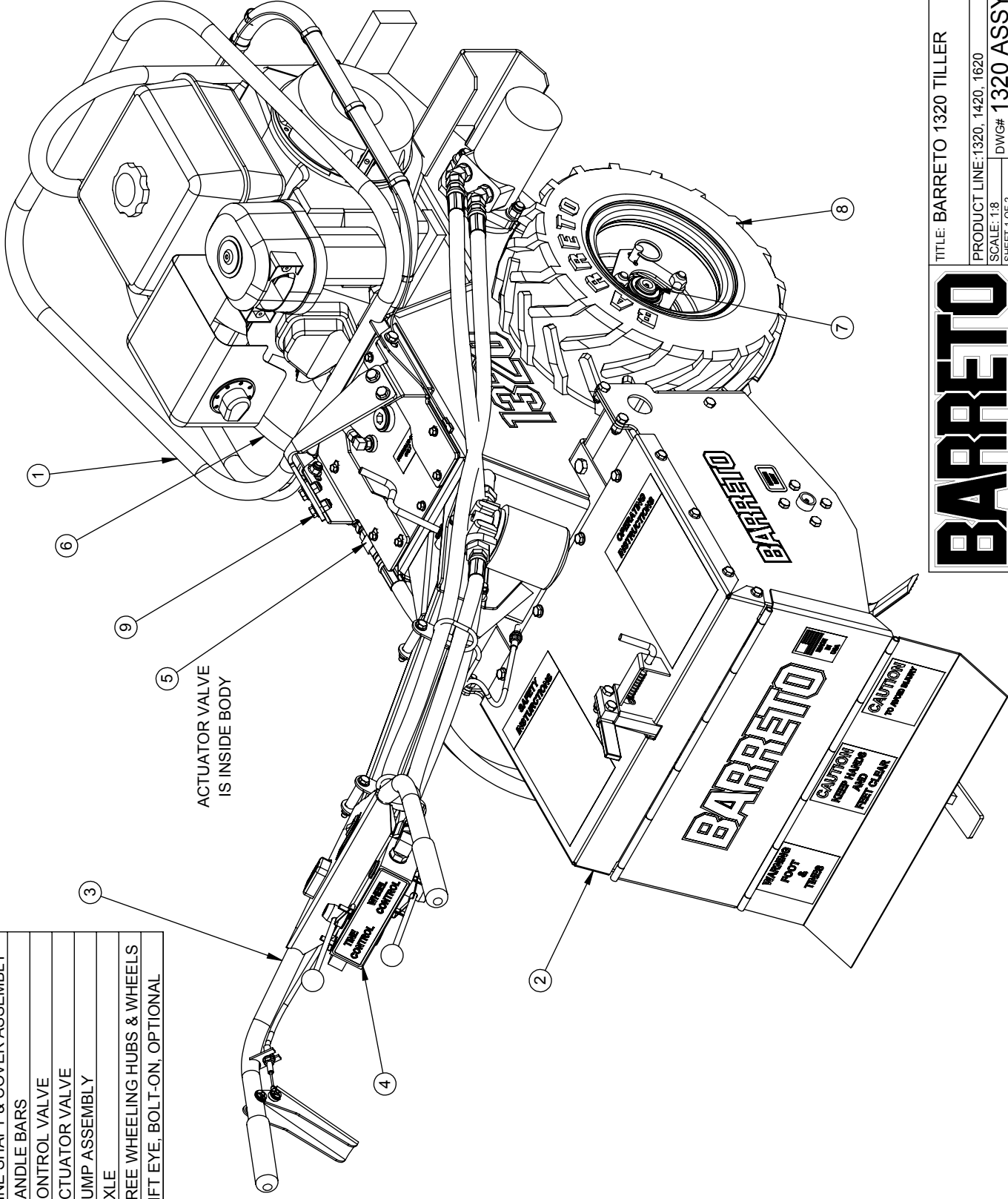

ACTUATOR VALVE
IS INSIDE BODY

BARRETO

TITLE: BARRETO 1320 TILLER

PRODUCT LINE: 1320, 1420, 1620

SCALE: 1:8

DWG# 1320 ASSY

SHEET 1 OF 2

RELEASE DATE	12/6/16
REVISED DATE	NEW
REVISION #	0

ITEM NO.	QTY.	PART NO.	DESCRIPTION
1	1	00279 R5	1620 BODY ASSEMBLY
2	1	00284-SPL	TINE SHAFT & COVER ASSEMBLY
3	1	00282 R1	HANDLE BARS
4	1	00280 R2	CONTROL VALVE
5	1	00277	ACTUATOR VALVE
6	1	00283 R1	PUMP ASSEMBLY
7	1	00278 R1	AXLE
8	1	10388	FREE WHEELING HUBS & WHEELS

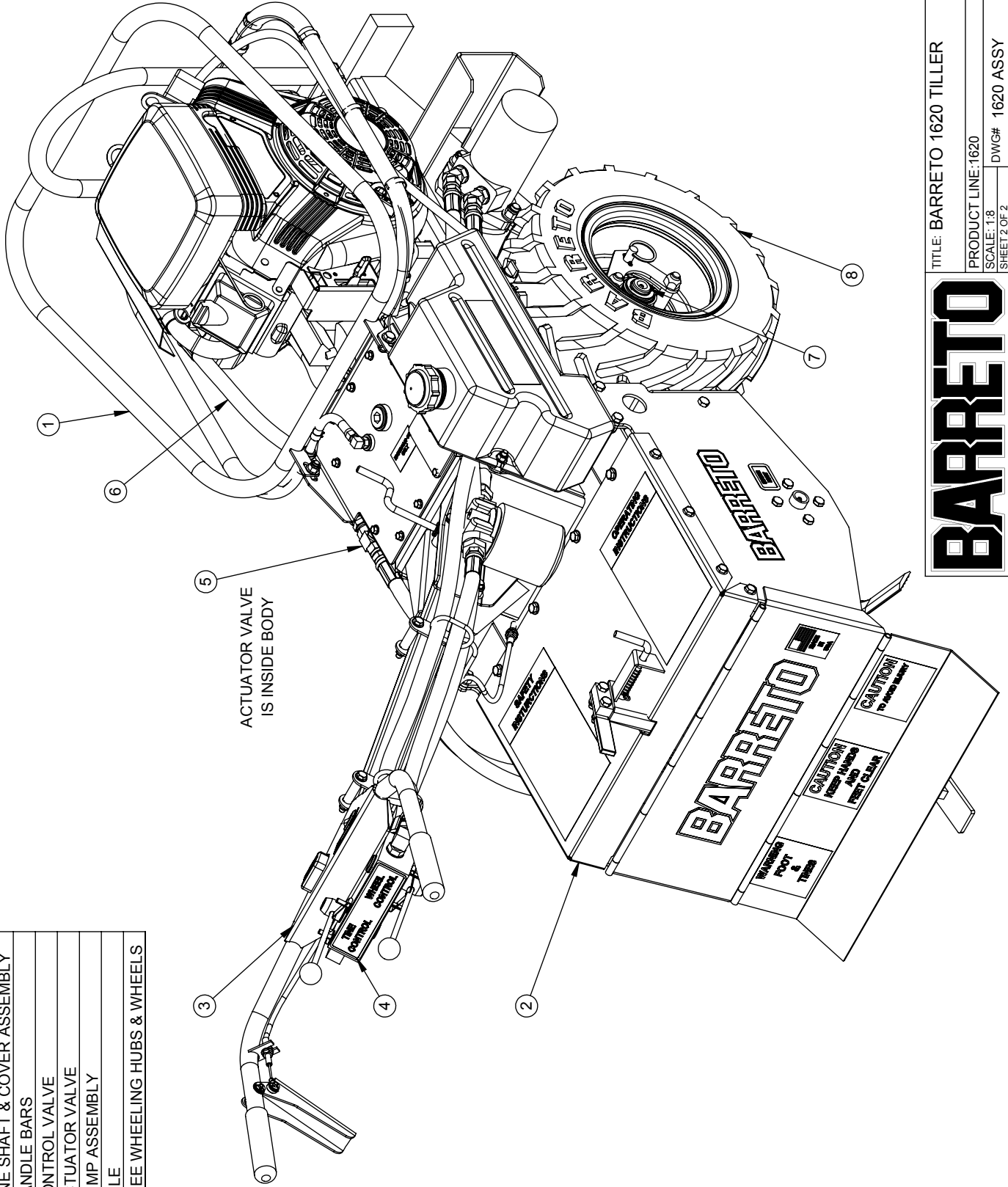

TITLE: BARRETO 1620 TILLER

PRODUCT LINE: 1620

SCALE: 1:8

DWG# 1620 ASSY

BARRETO

1320/1620 Tiller decals

P/N 03040

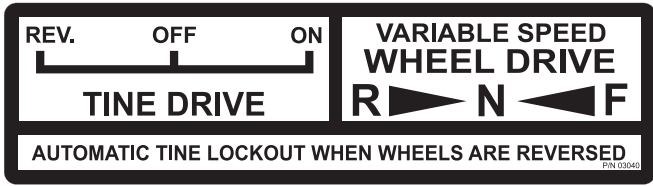

P/N 03040-01



P/N 03040-02



P/N 03040-03



P/N 03040-04



P/N 03040-06



P/N 03040-07

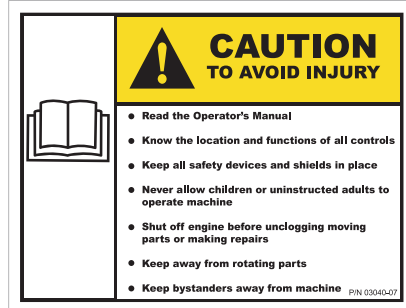

P/N 03040-08



P/N 03040-11



P/N 03040-09



P/N 03040-10



P/N 03040-57



P/N 03040-59



P/N 03341-07



P/N 03341-22

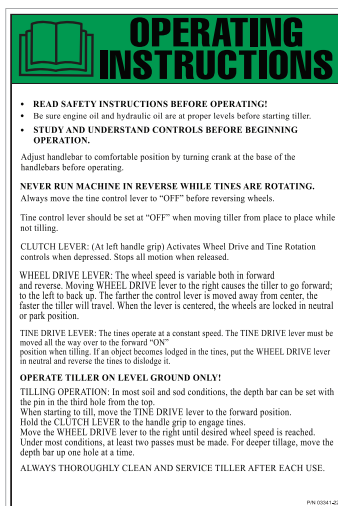

P/N 03341-23

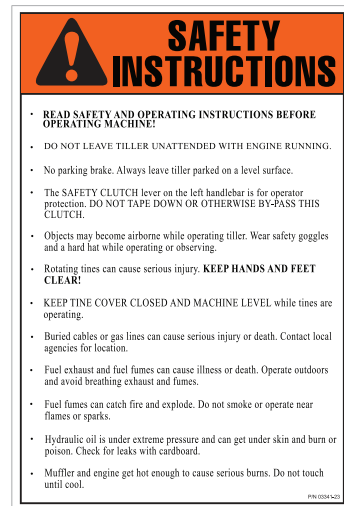



Recycling



ENVIRONMENTAL PROTECTION: Please recycle any unwanted materials as opposed to disposing them as general waste. It is recommended the original is retained and used to store the product when not in use for prolonged periods of time. If this is not applicable ensure the materials are sorted and recycled in accordance with local regulations.



SPECIFICATION CHANGE: It is our policy to continually improve products to ensure these meet the rigours of the industry we serve. Therefore, as such we reserve the right to alter specifications, data, components & parts with-out prior notice.

WARRANTY: Please refer to the manufactures terms & conditions.

IMPORTANT: No liability will be accepted for the incorrect use of this product.

KEEP THIS BOOKLET FOR FUTURE REFERENCE

📞 Nottingham: 0115 946 1988 • London: 0208 830 3333 ✉ Nottingham: sales@hscgroupuk.co.uk • London: sean@hscgroupuk.co.uk 🌐 www.hscgroupuk.co.uk

The Hire Supply Company Terms & Conditions Apply At All Time E&OE