



PARTS DRAWING



**240v 27ltr Professional
Dehumidifier**

**Product Code:
DH26**



Serial Number Range:

From:

To:

Year Of Manufacture: 2013

***Please note, when ordering online via our website if the part number is not recognised,
please Email spares@hscgroupuk.co.uk or Telephone 0115 946 1988**

KEEP THIS BOOKLET FOR FUTURE REFERENCE

📞 Nottingham: 0115 946 1988 • London: 0208 830 3333 ✉ Nottingham: sales@hscgroupuk.co.uk • London: sean@hscgroupuk.co.uk 🌐 www.hscgroupuk.co.uk

The Hire Supply Company Terms & Conditions Apply At All Time E&OE

MASTER[®]

CLIMATE SOLUTIONS

DEHUMIDIFIERS

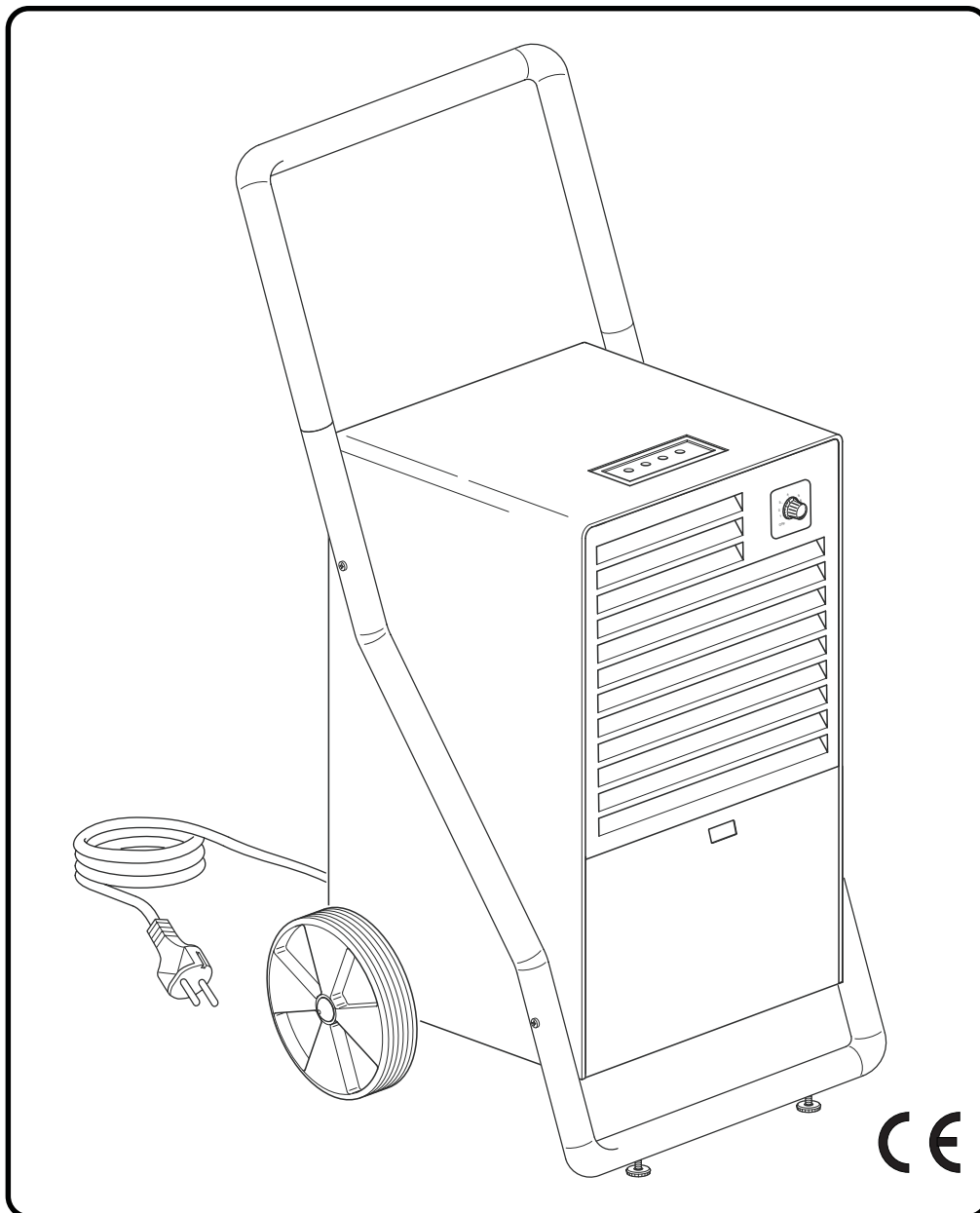

GB

DH 26

SPARE PARTS DISASSEMBLY

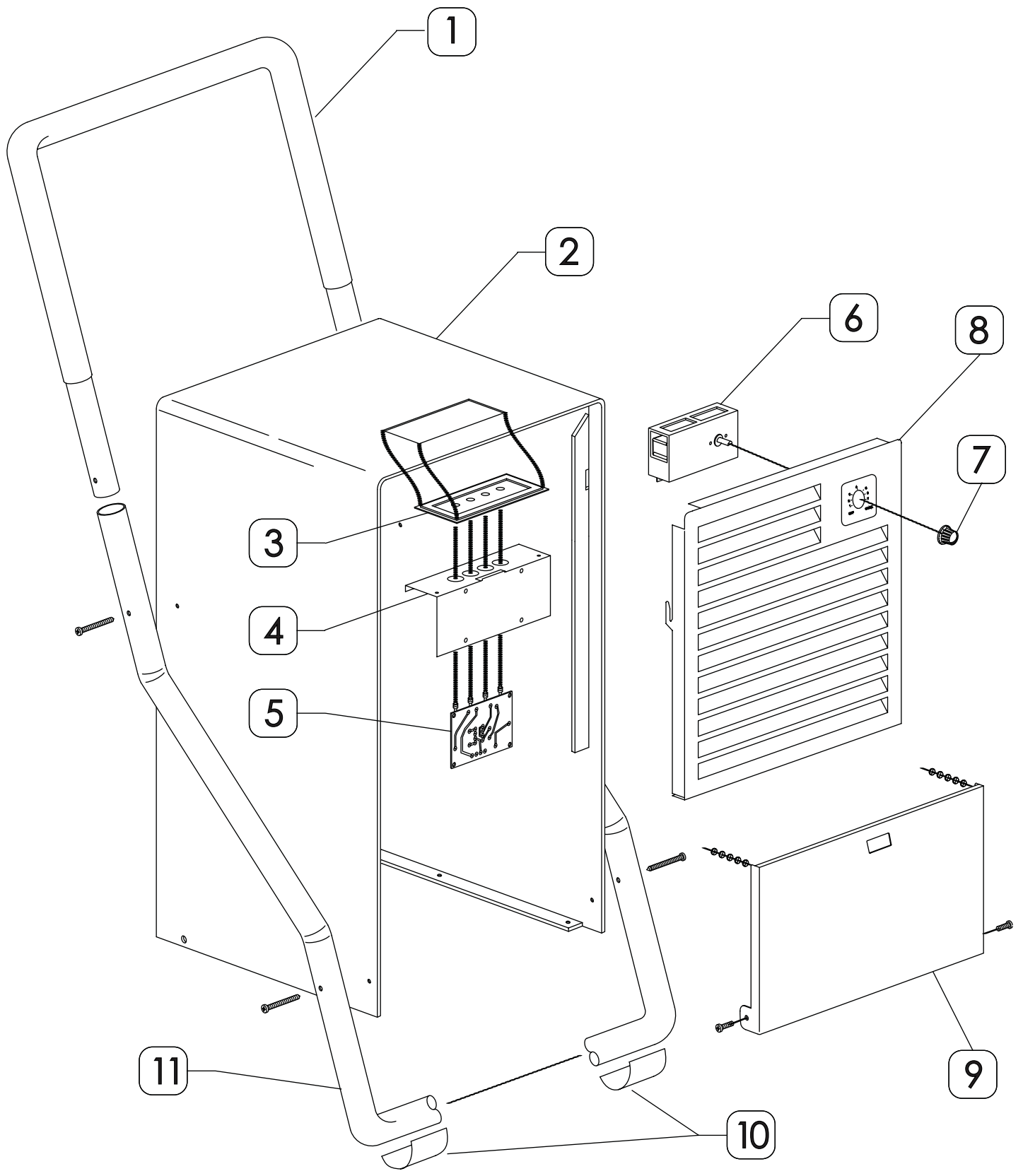

MODEL DH 26

UNIT 2

ILLUSTRATED PARTS BREAKDOWN

Rev. -- Apr. 2013

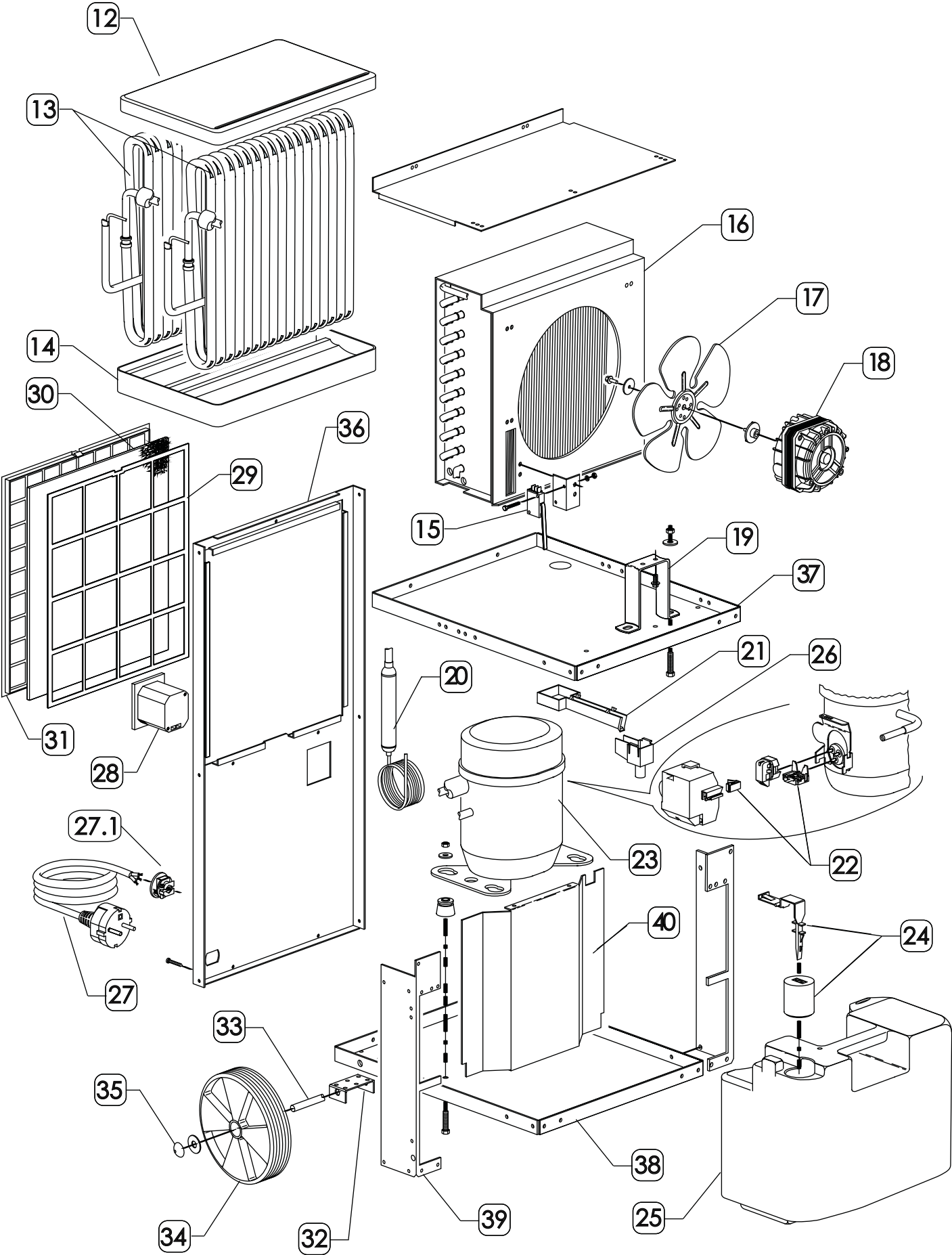

DEHUMIDIFIER DH 26

UNIT3

PARTS LIST

Pos.	Code NR	Description	Rev.- - Apr.2013
1	4140.342	Handle	
2	S/R	Metal cover	
3	4140.205	Control panel with silkscreen printing	
4	4140.206	Support pcb	
5	4140.201	PCB	
6	4140.245	Dehumidostat	
7	4140.291	Knob	
8	S/R	Grille	
9	4140.108	Front door	
10	4140.234	Foot	
11	4140.300	Pipe handle	
12	4140.292	Top tray	
13	4140.293	Evaporator	
14	4140.294	Lower condensate collecting tray	
15	4140.268	Microswitch with support	
16	4140.269	Condenser	
17	4140.270	Impeller	
18	4140.271	Motorfan	
19	4140.272	Fan bracket	
20	4140.273	Refrigerant filter with capillary	
21	4140.274	Water tray conveyor	
22+23	4140.275	Compressor starting group	
	4140.276	Compressor	
24	4140.277	Float with tank	
25	4140.278	Tank	
26	4140.279	Fitting for waste pipe	
27	4140.280	Power cord	
27.1	4140.349	Strain relief	
28	4140.158	Hour counter	
29+30+	4140.281	Air filter lock	
31	4140.259	Air filter	
	4140.260	Air filter holder	
32+33	4140.282	Support axis wheel	
	S/R	Wheel axis	
+34+35	4140.283	Wheel	
	4140.284	Cover	
36	4140.285	Rear panel	
37	4140.286	Upper bottom	
38	4140.287	Bottom fitting	
39	4140.182	Risers	
40	4140.183	Vertical panel	
41	4140.289	Inside wiring	
42	4140.184	Support evaporator	

S/R - PARTS AVAILABLE BY SPECIAL REQUEST ONLY

ESP00057



Recycling



ENVIRONMENTAL PROTECTION: Please recycle any unwanted materials as opposed to disposing them as general waste. It is recommended the original is retained and used to store the product when not in use for prolonged periods of time. If this is not applicable ensure the materials are sorted and recycled in accordance with local regulations.



SPECIFICATION CHANGE: It is our policy to continually improve products to ensure these meet the rigours of the industry we serve. Therefore, as such we reserve the right to alter specifications, data, components & parts with-out prior notice.

WARRANTY: Please refer to the manufactures terms & conditions.

IMPORTANT: No liability will be accepted for the incorrect use of this product.

KEEP THIS BOOKLET FOR FUTURE REFERENCE

📞 Nottingham: 0115 946 1988 • London: 0208 830 3333 ✉ Nottingham: sales@hscgroupuk.co.uk • London: sean@hscgroupuk.co.uk 🌐 www.hscgroupuk.co.uk

The Hire Supply Company Terms & Conditions Apply At All Time E&OE