



USER MANUAL



Master Dual Voltage 56ltr De Humidifier

**Product Code:
DHP65DV**



Serial Number Range:

From:

To:

Year Of Manufacture: 2015

***Please note, when ordering online via our website if the part number is not recognised, please Email spares@hscgroupuk.co.uk or Telephone 0115 946 1988**

KEEP THIS BOOKLET FOR FUTURE REFERENCE

Nottingham: 0115 946 1988 • London: 0208 830 3333 ✉ Nottingham: sales@hscgroupuk.co.uk • London: sean@hscgroupuk.co.uk 🌐 www.hscgroupuk.co.uk

The Hire Supply Company Terms & Conditions Apply At All Time E&OE











MASTER[®]
CLIMATE SOLUTIONS
MCS



USER AND MAINTENANCE BOOK	en
LIBRETTO USO E MANUTENZIONE	it
BEDIENUNGS- UND WARTUNGSANLEITUNG	de
MANUAL DE INSTRUCCIONES PARA EL USO Y MANTENIMIENTO	es
MANUEL D'UTILISATION ET DE MAINTENANCE	fr
HANDLEIDING VOOR GEBRUIK EN ONDERHOUD	nl
MANUAL DE USO E MANUTENÇÃO	pt
VEJLEDNING OM BRUG OG VEDLIGEHODELSE	da
KÄYTTÖ- JA HUOLTO-OHJE	fi
HEFTE FOR BRUK OG VEDLIKEHOLD	no
ANVÄNDAR- OCH UNDERHÅLLSHANDBOK	sv
INSTRUKCJA OBSŁUGI I KONSERWACJI	pl
РУКОВОДСТВО ПО ЭКСПЛУАТАЦИИ И ТЕХНИЧЕСКОМУ ОБСЛУЖИВАНИЮ	ru
PŘÍRUČKA PRO POUŽITÍ A ÚDRŽBU	cs
HASZNÁLATI ÉS KARBANTARTÁSI KÉZIKÖNYV	hu
PRIROČNIK Z NAVODILI ZA UPORABO IN VZDRŽEVANJE	sl
KULLANIM VE BAKIM KİTAPÇIĞI	tr
KNJIŽICA O UPORABI I ODRŽAVANJU	hr
NAUDOJIMO IR PRIEŽIŪROS KNYGELĖ	lt
LIETOŠANAS UN TEHNISKĀS APKOPES GRĀMATIŅA	lv
KASUTUS- JA HOOLDUSJUHEND	et
LIVRET DE UTILIZARE ȘI ÎNTREȚINERE	ro
PRÍRUČKA PRE POUŽITIE A ÚDRŽBU	sk
НАРЪЧНИК ЗА ИЗПОЛЗВАНЕ И ПОДДРЪЖКА	bg
КЕРІВНИЦТВО З ЕКСПЛУАТАЦІЇ Й ТЕХНІЧНОГО ОБСЛУГОВУВАННЯ	uk
KNJIŽICOM O UPOTREBI I ODRŽAVANJU	bs
ΕΓΧΕΙΡΙΔΙΟ ΧΡΗΣΗΣ ΚΑΙ ΣΥΝΤΗΡΗΣΗΣ	el
使用和维护手册	zh
ПАЙДАЛАНУ ЖӘНЕ ТЕХНИКАЛЫҚ ҚЫЗМЕТ КӨРСЕТУ ЖЕТЕКШІЛІГІ	kk

DHP 45 - DHP 65
DHP 45DV - DHP 65DV

TECHNICAL DATA - DATI TECNICI - TECHNISCHE DATEN - DATOS TÉCNICOS - DONNÉES TECHNIQUES - TECHNISCHE GEGEVENS - DADOS TÉCNICOS - TEKNISCHE DATA - TEKNISSET TIEDOT - TEKNISCHE DATA - TEKNISKA DATA - DANE TECHNICZNE - ТЕХНИЧЕСКИЕ ДАННЫЕ - TECHNICKÉ ÚDAJE - MŰSZAKI ADATOK - TEHNIČNI PODATKI - TEKNİK VERİLER - TEHNIČKI PODACI - TECHNINIAI DUOMENYS - TEHNISKIE DATI - TEHNILISED ANDMED - DATE TEHNICE - TECHNICKÉ ÚDAJE - ТЕХНИЧЕСКИ ДАННИ - ТЕХНІЧНІ ДАНІ - TEHNIČKI PODACI - ТЕХНИКА ДАДОМЕНА - 技术参数 - ТЕХНИКАЛЫҚ КӨРСЕТКІШТЕР КЕСТЕСІ

MODEL	DHP 45	DHP 65	DHP 45DV	DHP 65DV
	38 ÷ 99 %	38 ÷ 99 %	38 ÷ 99 %	38 ÷ 99 %
	3 ÷ 35 °C	3 ÷ 35 °C	3 ÷ 35 °C	3 ÷ 35 °C
	500 m³/h-m³/ч	500 m³/h-m³/ч	500 m³/h-m³/ч	500 m³/h-m³/ч
	46 л-л / 24 h-ч	56 л-л / 24 h-ч	46 л-л / 24 h-ч	56 л-л / 24 h-ч
	R410A / 515 g-г GWP-Потенциал глобального потепления 1975	R410A / 530 g-г GWP-Потенциал глобального потепления 1975	R410A / 515 g-г GWP-Потенциал глобального потепления 1975	R410A / 530 g-г GWP-Потенциал глобального потепления 1975
	~220-240 V-B / 50 Hz-Гц 3,3 A 660 W-Вт	~220-240 V-B / 50 Hz-Гц 3,9 A 780 W-Вт	~110/240 V-B / 50 Hz-Гц 6,7/3,3 A 680/660 W-Вт	~110/240 V-B / 50 Hz-Гц 7,9/3,9 A 810/790 W-Вт
dB(A)	53 dB-дБ	53 dB-дБ	53 dB-дБ	53 dB-дБ
	10,5 л-л	10,5 л-л	10,5 л-л	10,5 л-л
	42 kg-кг	45 kg-кг	48 kg-кг	51 kg-кг
	PS 41,5 - 33 Bar-Бар TS 65 - 55 °C LRA 16 A	PS 41,5 - 33 Bar-Бар TS 65 - 55 °C LRA 21 A	PS 41,5 - 33 Bar-Бар TS 65 - 55 °C LRA 32 A (110-120 V-B) LRA 16 A (220-240 V-B)	PS 41,5 - 33 Bar-Бар TS 65 - 55 °C LRA 42 A (110-120 V-B) LRA 21 A (220-240 V-B)
CO₂ Eq	1075,3	1106,6	1075,3	1106,6
GWP	2088	2088	2088	2088

* 30°C - UR 80% - при температуре 30°C и относительной влажности воздуха 80%

** 27°C - UR 60% - при температуре 27°C и относительной влажности воздуха 60%

 **IMPORTANT:** In order to have a correct function you must use an electrical generator in class G3 or more (frequency variation ±1%, tension variation ±2%). The maximum power of electrical generator must be three time the nominal power of device that you must connect.

**PICTURES - FIGURE - ABBILDUNGEN - FIGURAS - FIGURES - FIGUREN
 - FIGURAS - FIGURER - KUVAT - FIGURER - FIGURER - ILUSTRACJE
 - ИЛЛЮСТРАЦИИ - OBRÁZKY - ÁBRÁK - SLIKE - ŞEKİLLER - SLIKE -
 ILIUSTRACIJOS - ATTĒLI - JOONISED - IMAGINI - OBRÁZKY - СХЕМИ -
 МАЛЮНКИ - SLIKE - EIKONES - 图示 - СУРЕТТЕМЕЛЕР**

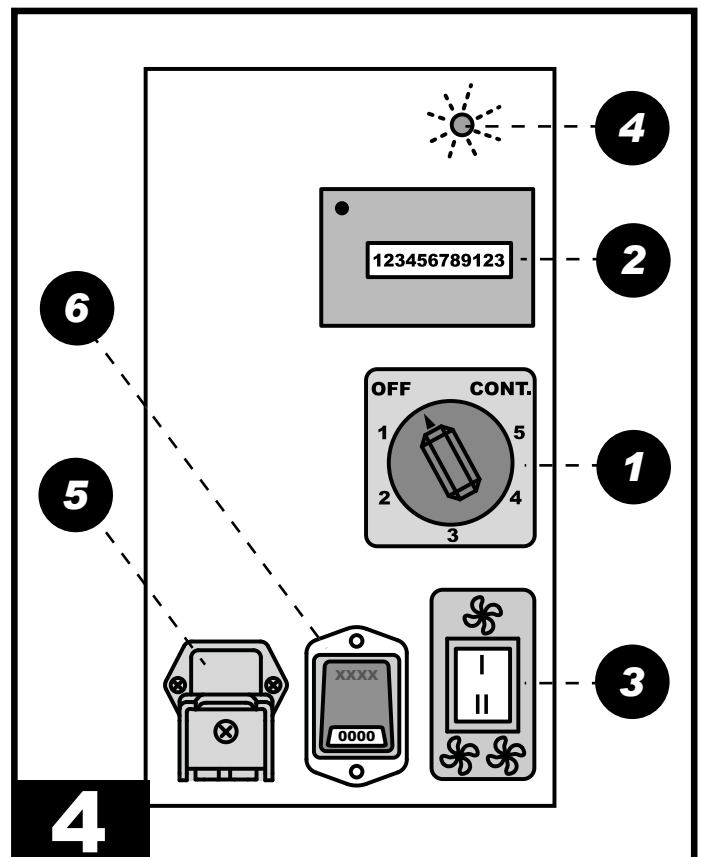
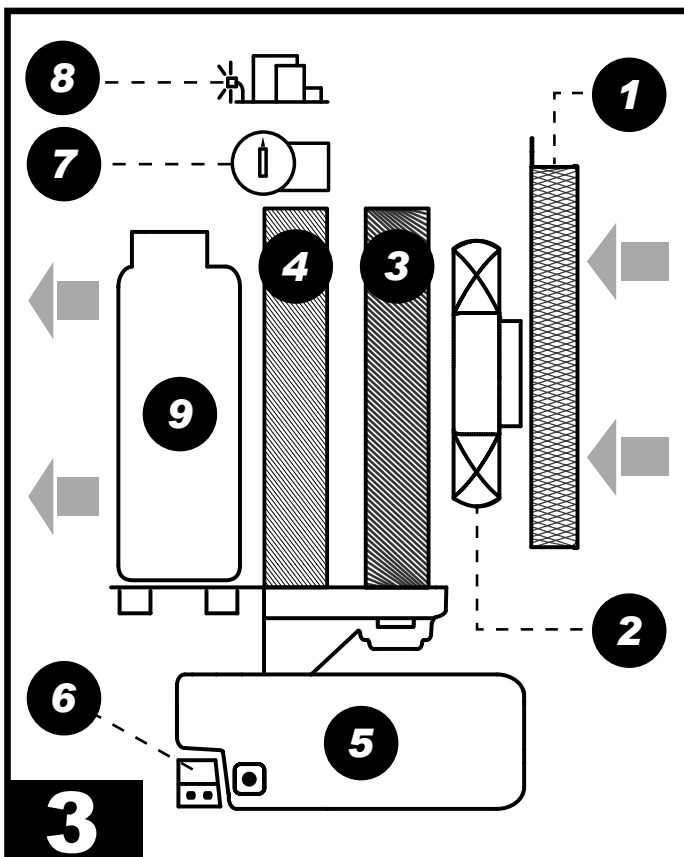
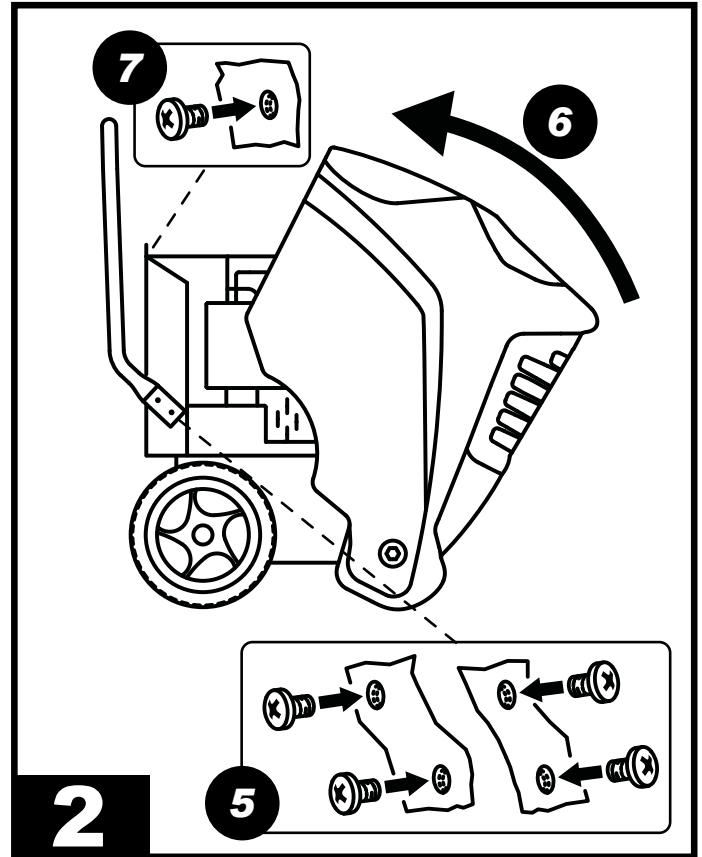
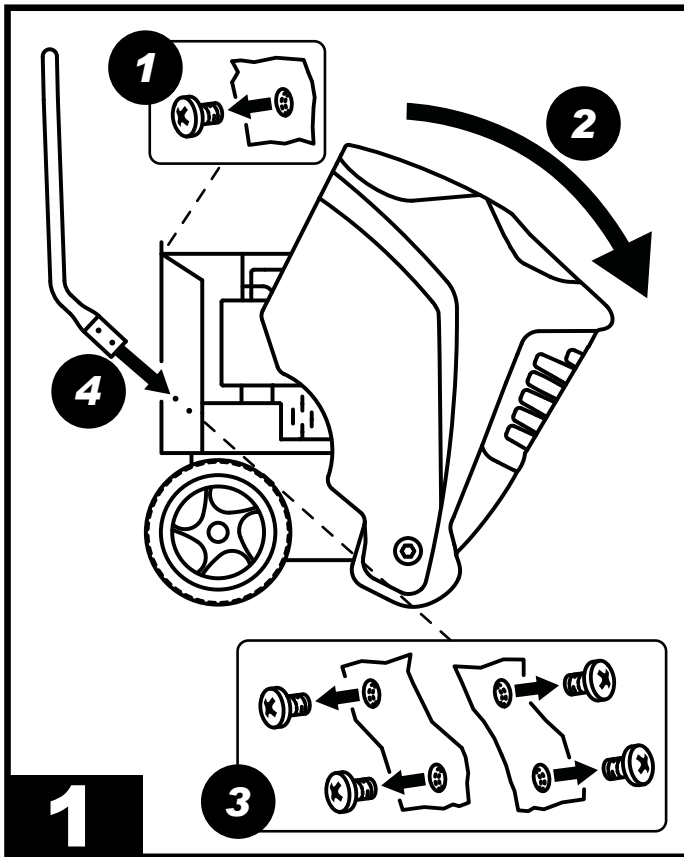

**PICTURES - FIGURE - ABBILDUNGEN - FIGURAS - FIGURES - FIGUREN
- FIGURAS - FIGURER - KUVAT - FIGURER - FIGURER - ILUSTRACJE
- ИЛЛЮСТРАЦИИ - OBRÁZKY - ÁBRÁK - SLIKE - ŞEKİLLER - SLIKE -
ILIUSTRACIJOS - ATTĒLI - JOONISED - IMAGINI - OBRÁZKY - СХЕМИ -
МАЛЮНКИ - SLIKE - ΕΙΚΟΝΕΣ - 图示 - СУРЕТТЕМЕЛЕР**

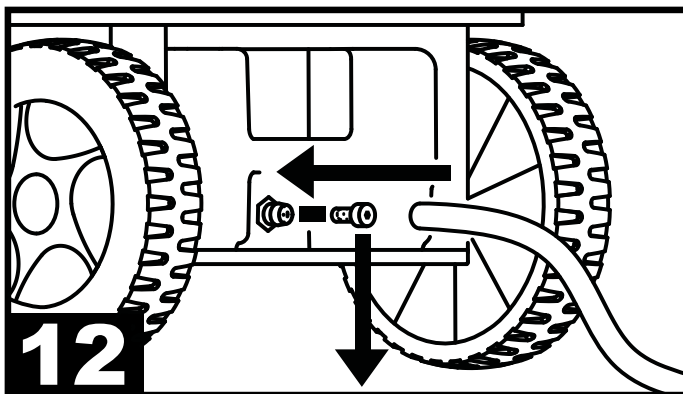
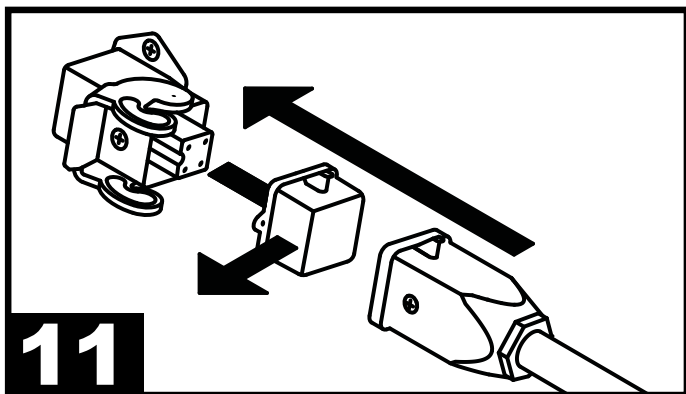
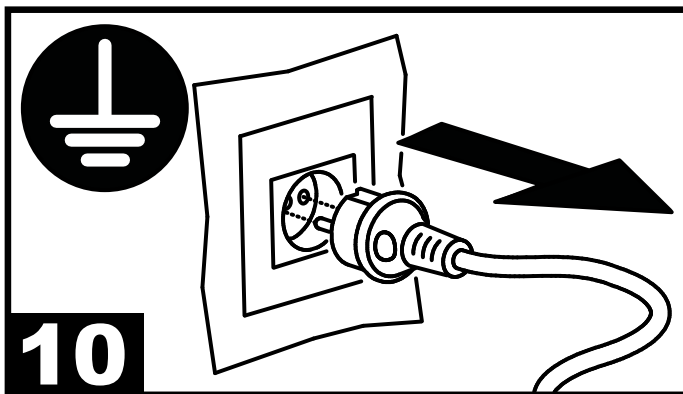
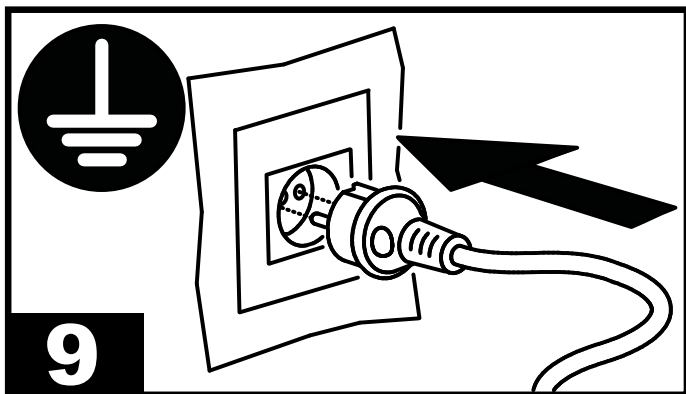
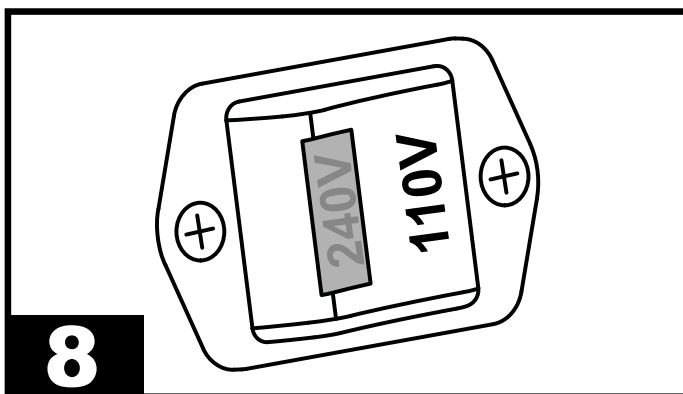
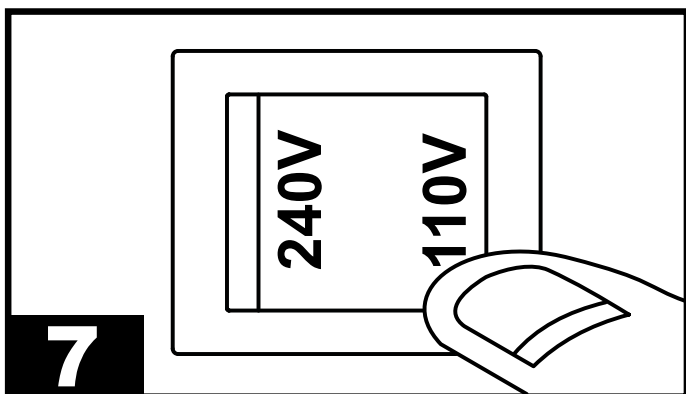
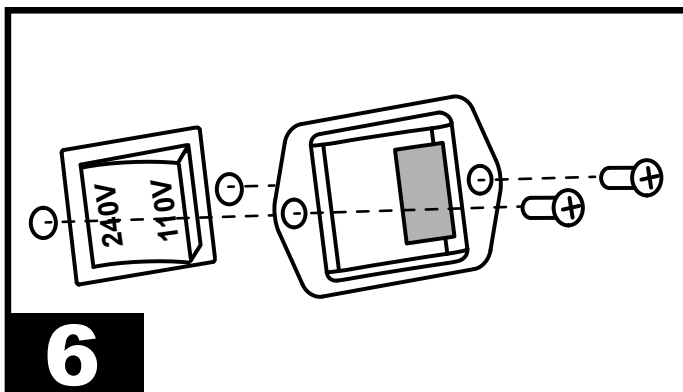
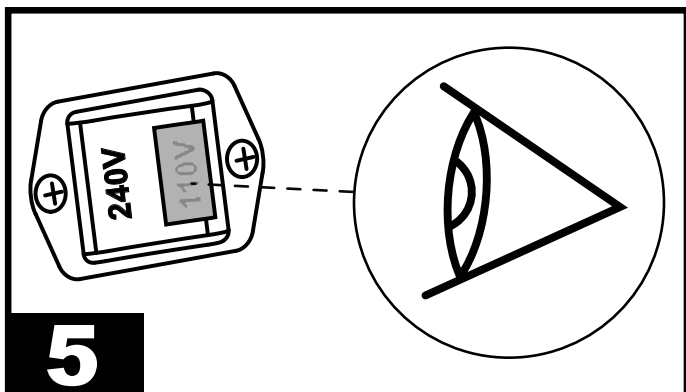

**PICTURES - FIGURE - ABBILDUNGEN - FIGURAS - FIGURES - FIGUREN
- FIGURAS - FIGURER - KUVAT - FIGURER - FIGURER - ILUSTRACJE
- ИЛЛЮСТРАЦИИ - OBRÁZKY - ÁBRÁK - SLIKE - ŞEKİLLER - SLIKE -
ILUSTRACIJOS - ATTĒLI - JOONISED - IMAGINI - OBRÁZKY - СХЕМИ -
МАЛЮНКИ - SLIKE - EIKONES - 图示 - СУРЕТТЕМЕЛЕР**

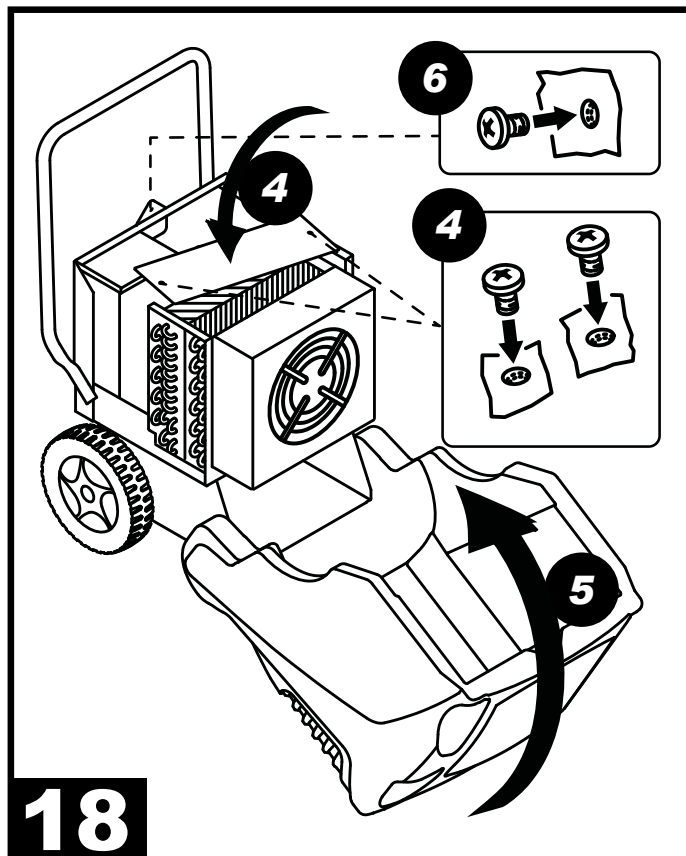
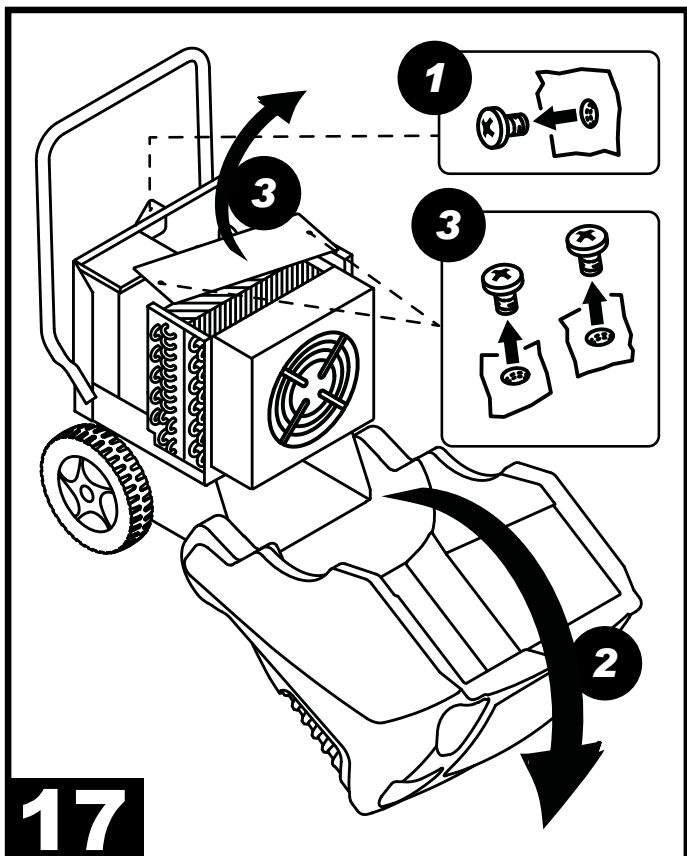
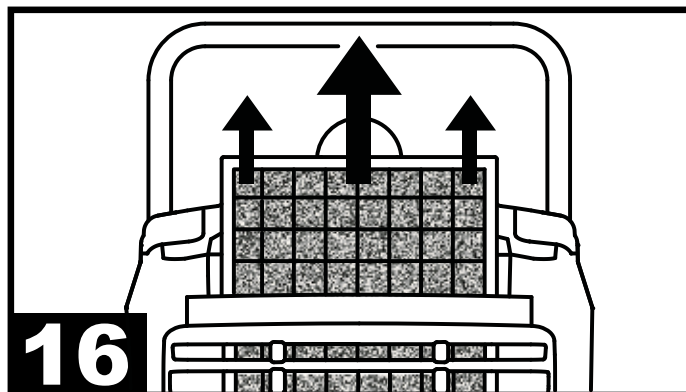
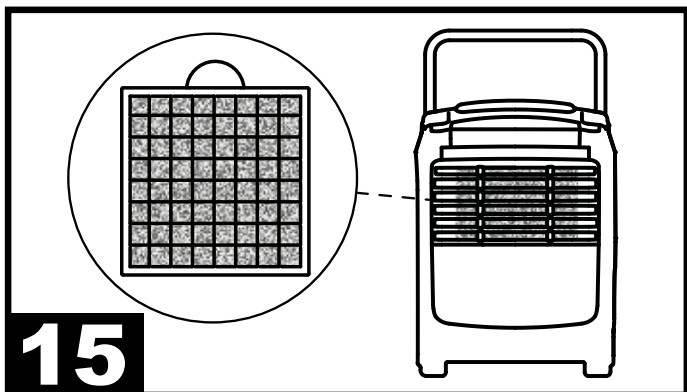
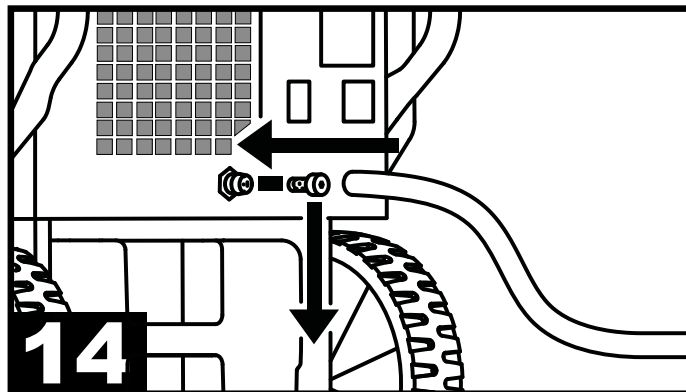
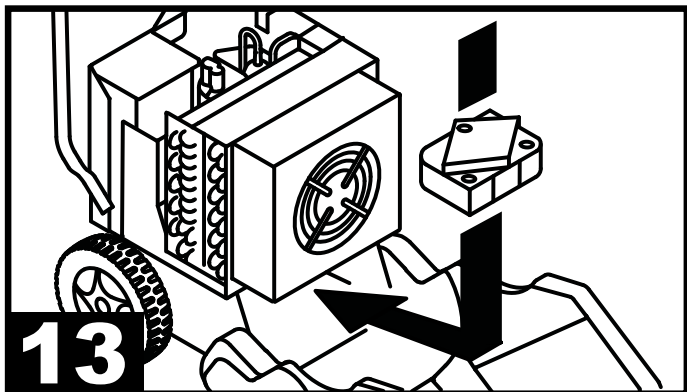

THE APPLIANCE IS SEALED AND CONTAINS FLUORINATED GREENHOUSE GASES GOVERNED BY THE KYOTO PROTOCOL. THE "GWP" IS SET OUT IN THE "TECHNICAL DATA TABLE".

IMPORTANT: BEFORE ANY MAINTENANCE, CLEANING, REPAIR OR OTHER, ALWAYS DISCONNECT THE PLUG FROM THE POWER MAINS. BEFORE RESTARTING THE DEHUMIDIFIER, ENSURE THE ELECTRICAL PARTS ARE NOT MOIST AND/OR WET.

►► 1. SAFETY WARNINGS

The dehumidifier must always be connected to power sockets fitted with earthing connection. Failure to comply with this rule - as for all electrical appliances - is a source of danger, for the consequences of which the manufacturer disclaims all liability.

The appliance may be disassembled exclusively by a skilled technician.

When the appliance is connected to a power socket it must be kept in vertical position and must not be subject to violent movements. Any water escaping from the tank might come in contact with electrical parts, with obvious hazardous consequences. It is therefore indispensable to disconnect the plug before moving the dehumidifier and empty the tank before lifting it.

In the event a water spillage should occur as a consequence of sudden motions, the dehumidifier must remain still in vertical position for at least eight hours before being switched on again.

This dehumidifier sucks air in from the front and expels it through the rear grille; therefore the front panel, which holds the air filter, must be kept at a distance of at least fifteen centimeters from the walls. Furthermore, the appliance must not be operated in narrow spaces which do not allow circulation of the air flowing out of the rear grille into the environment. However, the side panels may be drawn close to walls without creating any hindrance to regular operation. This dehumidifier has been constructed in compliance with the strictest safety regulations. However, no sharp objects such as screwdrivers, knitting irons or similar must be inserted in the grille or in the opening that remains exposed in the front panel when the filter is extracted: this is dangerous for persons and may damage the appliance.

To clean it outside you may use a moistened cloth after disconnecting the power plug from the electricity mains. Do not cover the front grille with linen or other objects, the appliance gets damaged and may cause danger.

Regularly clean the filter: cleaning must be performed on average every month; in the event of use in very dusty environments cleaning must be more frequent. See the relevant chapter for cleaning methods. When the filter is dirty the expelled air is warmer than usual, damaging the appliance and affecting performance.

►► 2. DESCRIPTION OF THE DEHUMIDIFIER

All portable dehumidifiers use the cooling cycle with compressor. The appliances are described below.

►► 3. ASSEMBLY OF THE DEHUMIDIFIER

This appliance is equipped with a handle. This component

is contained within the packaging of the dehumidifier.

To install the handle follow the below steps (Fig. 1-2):

- 3.1. Remove the screw that secures the cover to the dehumidifier (1);
- 3.2. Rotate the cover (2);
- 3.3. Remove the four screws located on the appliance side, two on the left side and two on the right side (3);
- 3.4. Place the handle in the proper position (4);
- 3.5. Install the four screws in their proper position, two on the left side and two on the right side (5);
- 3.6. Rotate the cover to bring it back to a vertical position (6);
- 3.7. Install the screw that secures the cover to the dehumidifier (7).

►► 4. OPERATION

This dehumidifier is a cooling cycle appliance whose operation is based on the physical principle by which when air comes into contact with a cold surface it wets it releasing moisture in the form of drops of condensation or ice, when the ambient temperature is not high.

In practice, a finned coil is maintained cold by a refrigerating machine, and the air that goes through it cools and dehumidifies. After that, the air goes through a heat exchanger and is heated, to finally flow back into the room dehumidified and at a slightly higher temperature than the initial one.

Reference to drawing (Fig. 3):

Air is extracted through the front of the dehumidifier: it goes through the filter (1), the fan (2), the cold exchanger (evaporator) (3), the hot exchanger (condenser) (4) and finally the dehumidified air flows out and is recirculated into the room through the rear grille. The condensed water is collected in the tank (5). A microswitch (6) stops the appliance when water in the tank reaches a certain level. The humidistat (7) allows the dehumidifier to operate when the humidity in the room is higher than the desired level. An electronic board (8) controls defrosting and prevents the compressor (9) from starting up too often, which is detrimental, and delays it.

These machines are fitted with a hot gas defrosting device, they are therefore equipped with a solenoid valve for hot gas bypass, a special electronic board and a defrosting thermostat.

The operation of the defrosting system is exclusive to our products: in practice a system with a thermostat and electronic control, it uses the hot gas bypass only for the time strictly necessary. This extends the dehumidifier's life and reduces the hot gas operation stage.

►► 5. CONTROL PANEL

The control panel (Fig. 4) is located at the rear of the dehumidifier and includes:

- 5.1. HUMIDISTAT (1): The humidistat carries a scale from 1 to 5. Setting the humidistat at the minimum value (1) means the dehumidifier operates until 80% relative humidity is achieved in the room. Setting the humidistat at the maximum value (5) means the dehumidifier operates until 20% relative humidity is achieved in the room. In the "CONT" position the dehumidifier works all the time regardless of the relative humidity reading. In the "OFF" position the dehumidifier never starts (unipolar switch).
- 5.2. HOUR COUNTER (2): The hour counter indicates the number of hours of operation of the dehumidifier.
- 5.3. VENTILATION SPEED SELECTOR (3): The ventilation speed selector allows the dehumidifier to

work at the maximum air flow or at an intermediate air flow depending on the need.

- ▶ 5.4. **ALARM LIGHT (4)**: The alarm light lights up when, in case of dehumidifier with tank, the tank is full or the direct exhaust is clogged up and in case of dehumidifier with pump (optional), there is a malfunctioning in the water discharge system. When the warning light comes on the dehumidifier does not work, reset the appliance to restart it.
- ▶ 5.5. **REMOTE HUMIDISTAT SOCKET (5)**: If a remote humidistat is connected to the socket, the relative humidity you wish to achieve in the room may be controlled remotely.
- ▶ 5.6. **VOLTAGE CHANGE SWITCH (6)** (where present): In dual voltage models (...DV), the dehumidifier operating voltage may be set to suit the voltage supplied by the electricity mains.

▶▶ 6. SWITCH-ON

IMPORTANT: In dual voltage models (...DV), check:

▶ **1-POSITION OF THE VOLTAGE CHANGE SWITCH (220-240V / 110-120V) (Fig. 5)**; If the set voltage does not match that supplied by the mains, the voltage must be adapted. Loosen the two screws fastening the cover (Fig. 6), move/press the switch on the supplied voltage value (Fig. 7) and refit the cover (Fig. 8).

▶ **2-CHECK THE TYPE OF SOCKET**; If the type of socket does not match the power supply features, a suitable adapter must be fitted.

IF THE VOLTAGE CHANGE SWITCH POSITION, THE TYPE OF SOCKET AND THE POWER SUPPLY ARE CONSISTENT, YOU MAY PROCEED WITH THE SWITCH ON SEQUENCE.

IMPORTANT: In dual voltage models (...DV), in the case you need to use a transformer 240V / 110V we suggest you to choose minimum power 2.000VA. You must use power cord extension with correct dimension (1,5mm² up to 10m, 2,5mm² up to 20m and 4mm² over 20m) and provided with ground connection.

In order to start up the dehumidifier, it must have remained in vertical position (normal use position) for at least eight hours. Failure to comply with this rule may cause irreparable damage to the dehumidifier.

- ▶ 6.1. Follow all the safety instructions;
- ▶ 6.2. Connect the supply plug to the power mains (Fig. 9) (SEE VOLTAGE IN THE "TECHNICAL DATA TABLE");
- ▶ 6.3. Turn the humidistat (1 Fig. 4) on the desired relative humidity value, the dehumidifier will start automatically. Thanks to the "VENTILATION SPEED" selector (3 Fig. 4), the dehumidifier may be operated at the maximum air flow or at an intermediate air flow depending on the need, in order to achieve the utmost comfort in the room.

▶▶ 7. SWITCH-OFF

Proceed as follows to switch off the dehumidifier:

- ▶ 7.1. Turn the humidistat (1 Fig. 4) to "OFF";
- ▶ 7.2. Disconnect the supply plug from the power mains with dehumidifier off (Fig. 10).

▶▶ 8. REMOTE HUMIDISTAT CONNECTION

For remote humidistat ready models (5 Fig. 4), remove the cover connected to the dehumidifier and connect

the remote humidistat (optional) (Fig. 11). For correct dehumidifier operation, completely rotate the knob of the humidistat on the control panel (1 Fig. 4) to "CONT" and set the desired humidity on the remote humidistat.

▶▶ 9. IF THE DEHUMIDIFIER DOES NOT START OR DOES NOT DEHUMIDIFY

If the "ALARM LIGHT" (4 Fig. 4) switches on, this means that the water recovery tank is full and/or there is pump malfunctioning (optional), just empty the tank and/or reset the pump. Should the problem persist, contact the authorised technical service centre.

▶▶ 10. CONNECTION TO DISCHARGE PIPING

This dehumidifier allows for the option to directly connect the appliance to a fixed discharge pipe.

▶ 10.1. **IN THE STANDARD CASE OF DEHUMIDIFIER WITH TANK**: The tank has a fitting which may be connected to a pipe with 16mm internal diameter. Before connecting the pipe, remove the screw/cover (where present) (Fig. 12) and check fitting cleanliness, in order to avoid possible obstructions.

▶ 10.2. **IN CASE OF DEHUMIDIFIER WITH PUMP (OPTIONAL)**: A water drain pump (optional) may be installed onto the dehumidifier (Fig. 13). Connection is easy and straightforward, thanks to the specific electrical connector and the hydraulic fitting located at the rear, which can be connected to a pipe with 16mm internal diameter. Before connecting the pipe, remove the screw/cover (where present) (Fig. 14) and check fitting cleanliness, in order to avoid possible obstructions. ALL INSTRUCTIONS AND DETAILS FOR INSTALLATION ARE SUPPLIED IN THE PUMP KIT.

▶▶ 11. PERIODIC MAINTENANCE

The only maintenance to be performed regularly is filter cleaning (Fig. 15). Cleaning must be performed by removing the filter from the front of the dehumidifier (Fig. 16) and placing it under the water tap in an ordinary sink. This must be performed on average every month; in the event of use in very dusty environments cleaning must be more frequent.

Depending on use, cleaning of the finned coil may be required, with a low pressure water jet. Before performing washing it is strictly required to disconnect the supply plug from the power mains (Fig. 10). To perform washing follow the below steps (Fig. 17-18):

- ▶ 11.1. Remove the screw that secure the cover to the dehumidifier (1);
- ▶ 11.2. Rotate the cover (2);
- ▶ 11.3. Remove the four screws and remove the protection from the finned coil (3). (Wash the finned coil with a low pressure water, paying attention not to wet the electrical panel. WATER MUST ONLY FLOW FROM THE TOP DOWN);
- ▶ 11.4. Install the protection and the two screws (4);
- ▶ 11.5. Rotate the cover to bring it back to a vertical position (5);
- ▶ 11.6. Install the screw than secures the cover to the dehumidifier (6).

Before restarting the dehumidifier, ensure the electrical parts are not wet and/or moist, in normal conditions at least eight hours must elapse. This cleaning operation improves the dehumidifier performance and assures its long life.

**ELECTRIC SYSTEM - IMPIANTO ELETTRICO - ELEKTRISCHE ANLAGE
 - INSTALACIÓN ELÉCTRICA - INSTALLATION ELECTRIQUE - ELEKTRISCH
 E INSTALATIE - SISTEMA ELÉTRICO - EL-ANLÆG - SÄHKÖLAITTEISTO -
 ELEKTRISK ANLEGG - ELANORDNING - INSTALACJA ELEKTRYCZNA -
 ЭЛЕКТРОПРОВОДКА - ELEKTRICKÉ ZAŘÍZENÍ - ELEKTROMOS RENDSZER -
 ELEKTRIČNA NAPELJAVA - ELEKTRİK TESİSATI - ELEKTRIČNI UREĐAJ -
 ELEKTROS SISTEMA - ELEKTRISKĀ SISTĒMA - ELEKTRISŪSTEEM -
 INSTALAȚIA ELECTRICĂ - ELEKTRICKÉ ZARIADENIE - ЭЛЕКТРИЧЕСКА
 ИНСТАЛАЦИЯ - ЕЛЕКТРИЧНЕ ОБЛАДНАННЯ - ELEKTRIČNI UREĐAJ -
 ΗΛΕΚΤΡΙΚΗ ΕΓΚΑΤΑΣΤΑΣΗ - 电路系统 - САЛЫНҒАН СЫМДАРДЫҒ СҮЛБЕСІ**

DHP 45
DHP 65

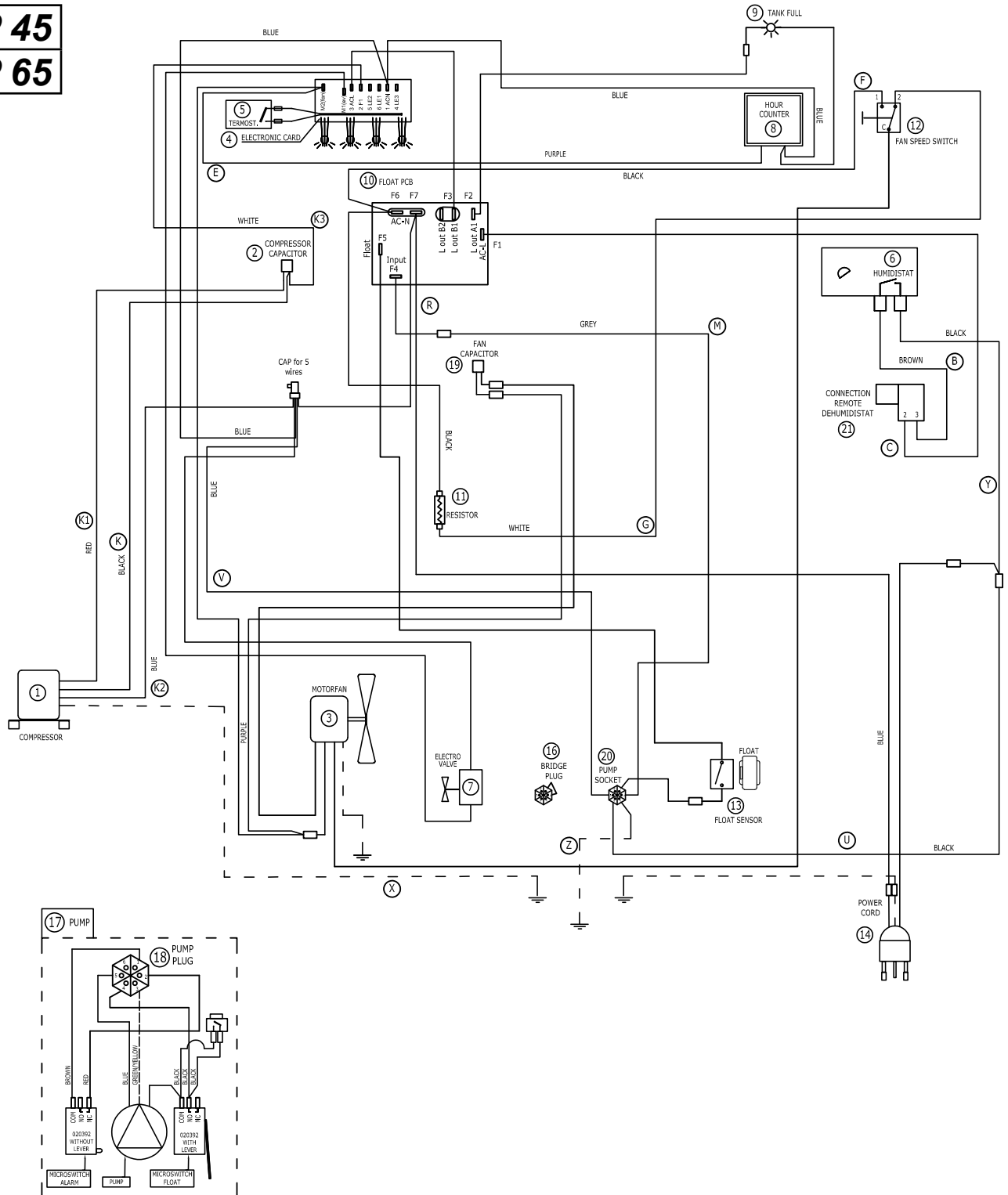

**ELECTRIC SYSTEM - IMPIANTO ELETTRICO - ELEKTRISCHE ANLAGE
 - INSTALACIÓN ELÉCTRICA - INSTALLATION ELECTRIQUE - ELEKTRISCH
 E INSTALLATIE - SISTEMA ELÉTRICO - EL-ANLÆG - SÄHKÖLAITTEISTO -
 ELEKTRISK ANLEGG - ELANORDNING - INSTALACJA ELEKTRYCZNA -
 ЭЛЕКТРОПРОВОДКА - ELEKTRICKÉ ZAŘÍZENÍ - ELEKTROMOS RENDSZER -
 ELEKTRIČNA NAPELJAVA - ELEKTRİK TEŞİSATI - ELEKTRIČNI UREĐAJ -
 ELEKTROS SISTEMA - ELEKTRISKÄ SYSTEMA - ELEKTRISÜSTEEM -
 INSTALAȚIA ELECTRICĂ - ELEKTRICKÉ ZARIADENIE - ЭЛЕКТРИЧЕСКА
 ИНСТАЛАЦИЯ - ЕЛЕКТРИЧНЕ ОБЛАДНАННЯ - ELEKTRIČNI UREĐAJ -
 ΗΛΕΚΤΡΙΚΗ ΕΓΚΑΤΑΣΤΑΣΗ - 电路系统 - САЛЫНҒАН СЫМДАРДЫҒ СҮЛБЕСІ**

DHP 45DV
DHP 65DV

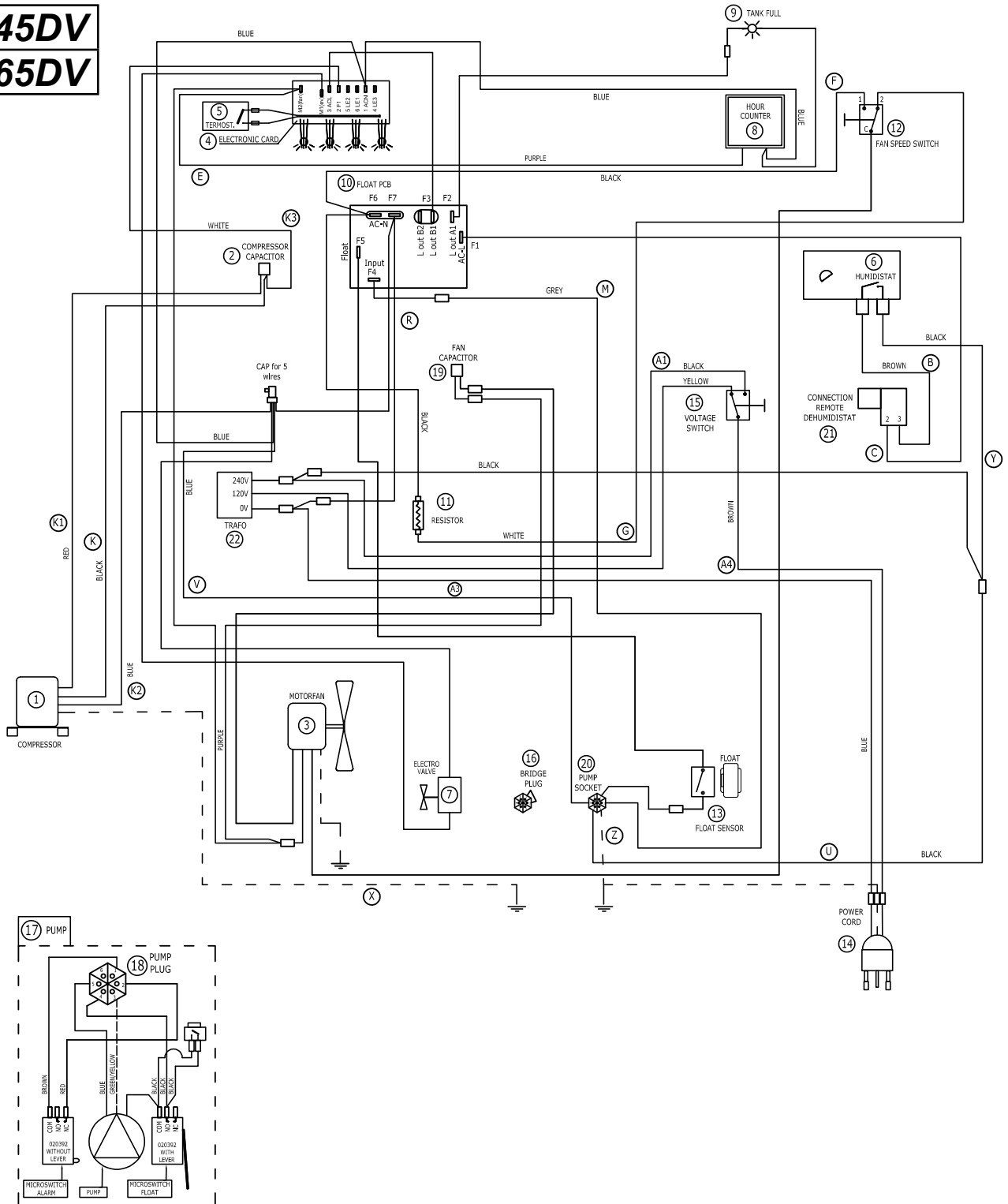

CE CONFORMITY CERTIFICATE



CE CONFORMITY CERTIFICATE - DICHIARAZIONE DI CONFORMITÀ CE - EG-KONFORMITÄT-SERKLÄRUNG - DECLARACIÓN DE CONFORMIDAD CE - DECLARATION DE CONFORMITE CE - EG-CONFORMITEITVERKLARING - DECLARAÇÃO DE CONFORMIDADE CE - EU-OVERENSSTEMMELSESERKLÆRING - EY-VAATIMUSTENMUKAISUUSVAKUUTUS - CE-SAMSVAR-SERKLÆRING - EG-FÖRSÄKRAN OM ÖVERENSSTÄMMELSE - DEKLARACJA ZGODNOŚCI WE - ДЕКЛАРАЦИЯ О СООТВЕТСТВИИ CE - PROHLÁŠENÍ O SHODĚ CE - EK MEGFELELŐSÉGI NYILATKOZAT - IZJAVA O SKLADNOSTI IN OZNAKA CE - CE UYGUNLUK BEYANI - IZJAVA CE O SUKLADNOSTI - ES ATITIKTIES DEKLARACIJA - EK ATBILSTĪBAS - DEKLARĀCIJA - EÜ VASTAVUSDEKLARATSIOON - DECLARAȚIE DE CONFORMITATE CE - PREHLÁSENIE O ZHODE CE - ДЕКЛАРАЦИЯ ЗА СЪВМЕСТИМОСТ CE - ДЕКЛАРАЦИЯ ВІДПОВІДНОСТІ CE - IZJAVA CE O PRIKLADNOSTI ΔΗΛΩΣΗ ΣΥΜΜΟΡΦΩΣΗΣ CE - CE 符合性声明

DANTHERM S.p.A. Via Gardesana 11, -37010- Pastrengo (VR), ITALY

Product: - Prodotto: - Produkt: - Producto: - Produit: - Product: - Produto: - Produkt: - Tuote: - Produkt: - Produkt: - Produkt: - Изделие: - Výrobek: - Termék: - Izdelek: - Ürün: - Proizvod: - Gaminys: - Ierīce: - Toode: - Produsul: - Výrobok: - Продукт: - Виріб: - Proizvod: - Προϊόν: - 产品:

DHP 45 - DHP 65 - DHP 45DV - DHP 65DV

We declare that it is compliant with: - Si dichiara che è conforme a: - Es wird als konform mit den folgenden Normen erklärt: - Se declara que está en conformidad con: - Nous déclarons sa conformité à: - Hierbij wordt verklaard dat het product conform is met: - Declara-se que está em conformidade com: - Vi erklærer at produktet er i overensstemmelse med: - Vakuutetaan olevan yhdenmukainen: - Man erklærer at apparatet er i overensstemmelse med: - Härmed intygas det att produkten är förenlig med följande: - Oświadczam, że jest zgodny z: - Заявляем о соответствии требованиям: - Prohlašuje se, že je v souladu s: - Kijelentjük, hogy a termék megfelel az alábbiaknak: - Izpolnjuje zahteve: - Aşağıdaki standartlara uygun olduğunu beyan ederiz: - Izjavljuje se da je u skladu s: - Pareiškiame, kad atitinka: - Tiek deklarēts, ka atbilst: - Käesolevaga deklareeritakse, et toode vastab: - Declarăm că este conform următoarelor: - Prehlasuje sa, že je v súlade s: - Декларира се че отговаря на: - Відповідає вимогам: - Izjavljuje se da je u skladu s: - Δηλώνουμε ότι είναι σύμφωνο με: - 兹证明符合:

2014/30/EU, 2014/35/EU, 2011/65/EU, 2009/125/EC, 2006/42/EC, 97/23/EC

**EN 55014-1:2006/A2:2011, EN 55014-2:2015, EN 60335-2-40:2003/A13:2012,
EN 50581:2012, (EU) N°. 327/2011**

Pastrengo, 2019

Stefano Verani (Member of the Board)

► en - DISPOSAL OF THE PRODUCT

-This product has been designed and manufactured with top-quality materials and components, which can be re-cycled and re-used. When a crossed-wheely bin symbol is attached to the product, it means that the product is protected by the, 2012/19/UE European Directive.

-Please obtain information regarding the local differentiated collection system for electrical and electronic products.

-Respect local Standards in force and do not dispose of old products as normal domestic waste. Correct disposal of the product helps to prevent possible negative consequences for health, the environment and mankind.

► it - SMALTIMENTO DEL PRODOTTO

-Questo prodotto è stato progettato e fabbricato con materiali e componenti di alta qualità, che possono essere riciclati e riutilizzati.

-Quando ad un prodotto è attaccato il simbolo del bidone con le ruote segnato da una croce, significa che il prodotto è tutelato dalla Direttiva Europea 2012/19/UE.

-Si prega di informarsi in merito al sistema locale di raccolta differenziata per i prodotti elettrici ed elettronici.

-Rispettare le norme locali in vigore e non smaltire i prodotti vecchi nei normali rifiuti domestici. Il corretto smaltimento del prodotto aiuta ad evitare possibili conseguenze negative per la salute dell'ambiente e dell'uomo.

► de - ENTSORGUNG DES PRODUKTS

-Dieses Produkt wurde unter Verwendung von Qualitätsmaterialien und -bauteilen entwickelt und hergestellt, die recycelt und wieder verwendet werden können.

-Ist ein Produkt gekennzeichnet durch die Mülltonne mit Rädern und einem Kreuz, wird hier angezeigt, dass dieses Produkt durch die europäische Direktive 2012/19/UE überwacht ist.

-Es wird gebeten, sich über die vor Ort bestehende Mülltrennung bezüglich elektrischer und elektronischer Produkte zu informieren.

-Die vor Ort geltenden Vorschriften zur Müllentsorgung müssen eingehalten werden und alte Produkte dürfen nicht zusammen mit dem Hausmüll entsorgt werden. Die ordnungsgemäße Entsorgung des Produkts hilft mögliche negative Folgen für Gesundheit und Umwelt zu vermeiden.

► es - ELIMINACIÓN DEL PRODUCTO

-Este producto ha sido diseñado y fabricado con materiales y componentes de alta calidad que se pueden reciclar y reutilizar.

-Cuando en el producto se encuentra el símbolo del contenedor con las ruedas tachado con una cruz, significa que el producto está tutelado por la Directiva europea 2012/19/UE.

-Se ruega informarse acerca del sistema local de recogida selectiva para los productos eléctricos y electrónicos.

-Respete las normas locales vigentes y no elimine los productos viejos junto con los residuos domésticos normales. La eliminación correcta del producto ayuda a evitar posibles consecuencias negativas para la salud del ambiente y del hombre.

► fr - SE DÉBARRASSER DE VOTRE PRODUIT USAGÉ

-Ce produit a été conçu et fabriqué avec des matériaux et des composants de haute qualité, qui peuvent être recyclés et utilisés de nouveau.

-Lorsque le symbole d'une poubelle à roue barrée est appliqué à un produit, cela signifie que le produit est couvert par la Directive Européenne 2012/19/UE.

-Veuillez vous informer du système local de séparation des déchets électriques et électroniques.

-Veuillez agir selon les règles locale set ne pas jeter vos produits usagés avec les déchets domestiques usuels. Jeter correctement votre produit usagé aidera à prévenir les conséquences négatives potentielles contre l'environnement et la santé humaine.

► nl - VERWIJDERING VAN HET PRODUCT

-Dit product werd ontworpen en gemaakt met hoogwaardige materialen en componenten, die gerecycleerd en herbruikt kunnen worden.

-Wanneer op een product het symbool van de afvalbak op wielen met een kruis erdoor is aangebracht, betekent dit dat het product valt onder de Europese Richtlijn 2012/19/UE.

-Gelieve inlichtingen in te winnen betreffende het plaatselijke systeem voor gedifferentieerde inzameling van elektrische en elektronische toestellen.

-Respecteer de plaatselijke normen die van kracht zijn, en verwijder de oude toestellen niet als gewoon huishoudelijk afval. Een correcte verwijdering van het product helpt om mogelijke negatieve gevolgen voor de gezondheid van mens en milieu te voorkomen.

► pt - ELIMINAÇÃO DO PRODUTO

-Este produto foi projetado e fabricado com materiais e componentes de alta qualidade que podem ser reciclados e reutilizados.

-Quando for afixado em um produto o símbolo do bidão com rodas marcado com uma cruz, significa que o produto é protegido pela Diretiva Europeia 2012/19/UE.

-Solicitamos informar-se sobre o sistema local de recolha diferenciada para os produtos elétricos e eletrônicos.

-Respeitar as normas locais em vigor e não eliminar os produtos antigos como normais detritos domésticos. A correta eliminação do produto ajuda a evitar possíveis consequências negativas para a saúde do ambiente e do homem.

► da - BORTSKAFFELSE

- Dette produkt er designet og fremstillet med materialer og dele af høj kvalitet, der kan genanvendes.
- Når et produkt er mærket med symbolet, der viser en affaldsspand på hjul med et kryds over, betyder det, at produktet er beskyttet af EF-Direktiv 2012/19/UE.
- Der henstilles til, at man informerer sig angående det lokale affaldssorteringssystem for elektriske og elektroniske produkter.
- De gældende lokale regler skal overholdes, og de gamle produkter må ikke bortskaffes sammen med husholdningsaffaldet. Ved at bortskaffe dette produkt korrekt, medvirker De til at forhindre eventuelle negative påvirkninger af miljøet og folkesundheden.

► fi - TUOTTEEN HÄVITTÄMINEN

- Tämä tuote on suunniteltu ja valmistettu korkealaatuisia materiaaleja ja osia käyttämällä, jotka voidaan kierrättää ja käyttää uudelleen.
- Kun tuotteeseen on kiinnitetty viivattu roskasäiliön merkki, se tarkoittaa, että tuotetta suojaa Euroopan yhteisön direktiivi 2012/19/UE.
- Hanki tietoja paikallisesta sähkö- ja elektroniikkaromujen erilliskeräyksestä.
- Noudata voimassa oleva määräyksiä äläkä hävitä vanhoja tuotteita kotitalousjätteiden mukana. Tuotteen oikea hävittäminen auttaa suojelemaan luontoa ja välttää väärän romutuksen aiheuttamien terveysriskien syntymistä.

► no - AVFALLSHÅNTERING

- Dette produktet er utformet og produsert med materialer og deler av høy kvalitet, og som kan gjenvinnes.
- Når det på et produkt finnes et symbol som forestiller en avfallsbeholder med et kryss over, betyr dette at produktet er underlagt EU-direktiv 2012/19/UE.
- Vennligst informer dere angående de lokale reglene som gjelder kassering av elektrisk og elektronisk avfall.
- Ta hensyn til gjeldende regelverk og ikke kast gamle produkter sammen med husholdningsavfall. Riktig avfallshåndtering av produktet bidrar til å unngå potensielle negative konsekvenser for miljøet og menneskenes helse.

► sv - PRODUKTENS BORTSKAFFANDE

- Den här produkten har projekterats och tillverkats med material och komponenter av hög kvalitet som kan återvinnas och återanvändas.
- När ett klistermärke med en symbol med överkorsad soptunna med hjul sitter på produkten, betyder detta att produkten är skyddad av Eu-direktiv 2012/19/UE.
- Vi ber er inhämta upplysningar vid er lokala återvinningsstation för elektriska och elektroniska produkter.
- Följ lokala gällande bestämmelser och skaffa inte bort förbrukade produkter i det vanliga hushållsavfallet. Ett korrekt bortskaffande av produkten hjälper till att undvika möjliga negativa effekter på miljö- och människohälsa.

► pl - UTYLIZACJA PRODUKTU

- Niniejszy produkt został wyprodukowany z najwyższej jakości materiałów, które mogą być poddane recyklingowi i zostać ponownie użyte.
- Symbol przekreślonego kosza na śmieci umieszczony na sprzęcie, opakowaniu lub dokumentach do niego dołączonych oznacza, że produktu nie wolno wyrzucać łącznie z innymi odpadami. Obowiązkiem użytkownika jest przekazanie zużytego sprzętu do wyznaczonego punktu zbiórki w celu właściwego jego przetworzenia. Oznakowanie oznacza jednocześnie, że sprzęt został wprowadzony do obrotu po dniu 13 sierpnia 2005 r.
- Należy zapoznać się z lokalnym systemem zbiórki produktów elektronicznych i elektrycznych.
- Informacje o dostępnym systemie zbierania zużytego sprzętu elektrycznego można znaleźć w punkcie informacyjnym sklepu oraz w urzędzie miasta/gminy.
- Odpowiednie postępowanie ze użytym sprzętem zapobiega negatywnym konsekwencjom dla środowiska i ludzkiego zdrowia!

► cs - LIKVIDACE VÝROBKU

- Tento výrobek byl navržen a vyroben z vysoce kvalitních materiálů a komponentů, které lze recyklovat a znovu použít.
- Je-li na výrobku symbol přeškrtnutého kontejneru, znamená to, že na výrobek se vztahuje Evropská Směrnice 2012/19/UE.
- Informujte se o místním systému pro oddělený sběr elektrických a elektronických výrobků.
- Dodržujte místní předpisy a nelikvidujte staré produkty spolu s běžným komunálním odpadem. Správná likvidace výrobku pomůže předcházet možným negativním dopadům na životní prostředí a lidské zdraví.

► hu - HULLADÉKBA HELYEZÉS

- A termék kiváló minőségű újrahazsnosítható és újból felhasználható alkotóelemek felhasználásával készült.
- Ha terméken elhelyezésre került az áthúzott hulladékgyűjtőt ábrázoló jel, az azt jelenti, hogy a termékre a 2012/19/UE irányelv vonatkozik.
- Kérjük, tájékozódjon az elektromos és elektronikus hulladékok szelektív gyűjtéséről.
- Tartsa be a helyben hatályos előírásokat, és ne a terméket ne helyezze a háztartási hulladékgyűjtőbe. A megfelelő hulladékgyűjtéssel elkerülhető, hogy a hulladékok károsítsák a környezetet ill. az emberi egészséget.

►sl - ODLAGANJE IZDELKA

- Ta izdelek je bil zasnovan in izdelan iz materialov in komponent visoke kakovosti, ki jih je mogoče reciklirati in ponovno uporabiti.
- Ko je izdelek označen z znamenjem prekrižanega smetnjaka na kolesih, pomeni, da zanj veljajo določbe evropske Direktive 2012/19/UE.
- Pozanimajte se o načinu ločenega zbiranja električne in elektronske opreme, ki velja v vašem kraju.
- Upoštevajte veljavne predpise in odsluženih izdelkov ne odlagajte med gospodinjske odpadke. Pravilno odlaganje izdelka prispeva k izogibanju morebitnim negativnim posledicam za zdravje okolja in ljudi.

►tr - ÜRÜNÜN İMHA EDİLMESİ

- Bu ürün, geri dönüştürülüp tekrar kullanılabilen, yüksek kaliteli malzeme ve bileşenler kullanılarak tasarlanıp üretilmiştir.
- Herhangi bir üründe, üzerinde çarpı işareti bulunan tekerlekli bidon bulunuyorsa bu, ürünün 2012/19/UE Avrupa Direktifi tarafından korunduğunu belirtir.
- Lütfen bulunduğunuz bölgedeki elektrikli ve elektronik aletler için olan çöp ayrıştırma sistemi ile ilgili bilgi edininiz.
- Konuyla ilgili yerel düzenlemelere uyunuz ve eski ürünleri normal evsel atıklarla beraber atmayınız. Ürünün doğru şekilde imha edilmesi, çevre ve insan sağlığını tehdit edici olumsuz sonuçların önlenmesine yardımcı olur.

►hr - ODBACIVANJE PROIZVODA

- Ovaj je proizvod osmišljen i izrađen s visokokvalitetnim materijalima i komponentama koje se mogu reciklirati i ponovno iskoristiti.
- Kada se na proizvod stavi simbol prekrižene kante na kotačima, to znači da je on podvrgnut Europskoj Smjernici 2012/19/UE.
- Informirajte se u svezi s lokalnim načinom diferencijalnog sakupljanja električnih i elektronskih proizvoda.
- Pošaljite lokalne propise na snazi i ne odbacujte stare proizvode zajedno sa običnim kućnim otpadom. Pravilnim odbacivanjem proizvoda spriječit ćete moguće negativne posljedice za okoliš i za zdravlje ljudi.

►lt - GAMINIO SUNAIKINIMAS

- Šis gaminys buvo sukurtas ir pagamintas iš aukštos kokybės medžiagų bei dalių, kurios gali būti perdirbtos arba panaudotos dar kartą.
- Kai gaminys yra pažymėtas perbraukto atliekų konteinerio su ratukais ženklų, tai reiškia, kad gaminys yra saugomas pagal ES direktyvą 2012/19/UE.
- Prašome pasidomėti apie vietinę elektros ir elektronikos atliekų rūšiavimo sistemą.
- Laikykitės vietinių galiojančių taisyklių ir nemeskite senų gaminių su įprastomis buitinėmis atliekomis. Tinkamai sunaikinę gaminių išvengsite galimų neigiamų pasekmių aplinkai ir žmonių sveikatai.

►lv - PRODUKTA IZNĪCINĀŠANA

- Šis produkts tika izveidots un ražots ar augstas kvalitātes materiāliem un sastāvdaļām, kas var būt savāktas un atkārtoti izmantotas.
- Kad pie produkta ir piestiprināts atkritumu tvertnes simbols ar riteņiem, kas ir pārsvītrots ar krustu, tas nozīmē, ka produktu aizstāv Eiropas Direktīva 2012/19/UE.
- Lūdzam Jūs gūt informāciju par vietēju centru, kas savāc elektriskās un elektroniskā ierīces.
- Ievērot vietējās pastāvošās normas un neiznīcināt vecus produktus, kā parastus mājas atkritumus. Produkta pareizā iznīcināšana palīdz izvairīties no iespējamām negatīvām sekām vides un cilvēku veselībai.

►et - TOOTE KASUTUSEST KÕRVALDAMINE

- See toode on projekteeritud ja toodetud kvaliteetsetest materjalidest ja osadest, mida võib uuesti ringlusse võtta ja korduskasutada.
- Kui tootel on märk, millel on ratastega prügikast, millele on rist peale tõmmatud, tähendab see, et toodet kaitseb Euroopa direktiiv 2012/19/UE.
- Palun tutvuge kohaliku elektri- ja elektroonikatoodete lahuskogumise süsteemiga.
- Täitke kehtivaid kohalikke õigusnorme ning ärge visake vana toodet olmejäätmete hulka. Toote õige kõrvaldamine aitab vältida võimalikke negatiivseid tagajärgi keskkonna ja inimeste tervisele.

►ro - SCOATEREA DEFINITIVĂ DIN UZ A PRODUSULUI

- Acest produs a fost proiectat și fabricat cu materiale și componente de înaltă calitate care pot fi reciclate și refolosite.
- Când pe produs este aplicat simbolul unei pubele cu roți, marcată cu o cruce, înseamnă că produsul respectiv este conform Directivei Europene 2012/19/UE.
- Vă rugăm să vă informați în ceea ce privește colectarea separată a produselor electrice și electronice.
- Respectați normele locale în vigoare și nu depozitați produsele vechi împreună cu deșeurile menajere. Eliminarea corectă a produsului ajută la eliminarea consecințelor negative pe care acesta le poate avea asupra mediului înconjurător și a persoanelor.

►sk - LIKVIDÁCIA VÝROBKU

- Tento výrobok bol navrhnutý a vyrobený z vysoko kvalitných materiálov a komponentov, ktoré je možné recyklovať a znovu použiť.
- Ak je na výrobku symbol prečiarknutého kontajnera, znamená to, že na výrobok sa vzťahuje Európska Smernica 2012/19/UE.
- Informujte sa o miestnom systéme pre oddelený zber elektrických a elektronických výrobkov.
- Dodržujte miestne predpisy a nelikvidujte staré produkty spolu s bežným komunálnym odpadom. Správna likvidácia výrobku pomôže predchádzať možným negatívnym dopadom na životné prostredie a ľudské zdravie.

► **bg - ИЗХВЪРЛЯНЕ НА УРЕДА**

-Това изделие е проектирано и произведено с материали и компоненти от високо качество, които могат да се рециклират или използват повторно.

-Когато на някое изделие е поставен символ с бидон на колелца, маркиран с хикс, това означава, че изделието е защитено съгласно Европейска Директива 2012/19/UE.

-Моля да се информирате относно местанат система за разделно изхвърляне на електрически и електронни изделия.

-Спазвайте действащите местни нормативи и не изхвърляйте изделията, заедно с нормалните домакински отпадъци. Правилното изхвърляне на изделията, помага за избягване на възможни отрицателно последици, за здравето на хората и за опазване на околната среда.

► **uk - УТИЛІЗАЦІЯ ВИРОБУ**

-Цей виріб був спроектований і вироблений з використанням високоякісних матеріалів і комплектуючих, які можуть бути повторно перероблені і використані.

-Якщо на виріб нанесено символ перекресленого бака з колесами для сміття, це означає, що виріб відповідає Директиві Європейського Союзу 2012/19/UE.

-Просимо ознайомитися з інформацією щодо місцевої системи роздільного збору сміття для електричного і електронного обладнання.

-Дотримуйтесь чинних місцевих правил і не викидайте старі вироби до звичайних побутових відходів. Правильна утилізація виробу допомагає уникнути можливих негативних наслідків для довкілля і здоров'я людей.

► **bs - ODLAGANJE PROIZVODA**

-Ovaj je proizvod dizajniran i proizveden korištenjem materijala i komponenata visoke kvalitete koji se mogu reciklirati i ponovo koristiti.

-Kada se na ovaj proizvod postavi simbol prekrizene kante /obilježene krstom na točkovima, to znači da je proizvod podložan Evropskoj Direktivi 2012/19/UE.

-Molimo Vas da se informirate o lokalnom sistemu diferencijalnog sakupljanja električnih i elektronskih proizvoda.

-Poštujte lokalne propise na snazi i ne odbacujte stare proizvode u obični kućanski otpad. Pravilno odlaganje proizvoda pomaže i onemogućuje negativne posljedice za zdravlje ljudi i okoliša

► **el - ΔΙΑΘΕΣΗ ΤΟΥ ΠΡΟΪΟΝΤΟΣ**

-Το προϊόν αυτό σχεδιάστηκε και κατασκευάστηκε με υλικά και εξαρτήματα υψηλής ποιότητας, τα οποία μπορούν να ανακυκλωθούν και να ξαναχρησιμοποιηθούν.

-Όταν ένα προϊόν είναι συνδεδεμένο με το σύμβολο του διαγεγραμμένου τροχοφόρου σημειωμένο με ένα σταυρό, σημαίνει ότι το προϊόν καλύπτεται από την Ευρωπαϊκή Οδηγία 2012/19/UE.

-Σας συνιστούμε να ενημερωθείτε σχετικά με το τοπικό σύστημα συλλογής για την ανακύκλωση ηλεκτρικών και ηλεκτρονικών προϊόντων.

-Τηρήστε τους τοπικούς κανονισμούς που ισχύουν και μην απορρίπτετε τα παλαιά προϊόντα στα οικιακά απορρίμματα. Η σωστή διάθεση του προϊόντος βοηθά στην αποφυγή πιθανών αρνητικών συνεπειών για την υγεία του περιβάλλοντος και του ανθρώπου.

► **zh - 弃置旧的产品**

-该产品是由高质量的原材料和零配件生产而成的，可以进行回收再利用

-当这个标识标签出现在产品上时，它表明这个产品符合 European Directive 2012/19/UE 标准。

-请熟知产品实际使用地关于处理废弃的电子元件的相关法律规定。

-请严格根据当地法规处理废弃的产品和包装，并确保不和生活垃圾混装。正确的处理方式可以避免对环境和人体健康产生的潜在威胁。

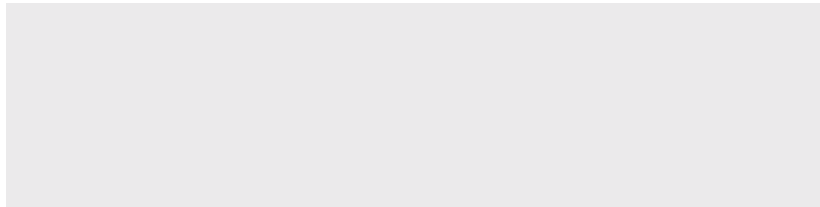

Dantherm S.p.A.

Via Gardesana 11, -37010-
Pastrengo (VR), Italy

Dantherm S.p.A.

Виа Гардесана 11, 37010
Пастренго (Верона), Италия

Dantherm Sp. z o.o.

ul. Magazynowa 5A,
62-023 Gądkі, Poland

Dantherm Sp. z o.o.

ул. Магазинова, 5А,
62-023 Гадки, Польша

Dantherm LLC

ul. Transportnaya - 22 ownership 2,
142802, STUPINO, Moscow region, Russia

ООО «Дантерм»

Ул. Транспортная, владение 22/2,
142802, г.Ступино, Московская обл., РФ

Dantherm China LTD

Unit 2B, 512 Yunchuan Rd.,
Shanghai, 201906, China

Dantherm China LTD

Юньчуань роад, 512, строение 2В,
Шанхай, 201906, Китай

Dantherm SP S.A.

C/Calabozos, 6 Polígono Industrial, 28108
Alcobendas (Madrid) Spain

Dantherm SP S.A.

Ц/Калабозос, 6 Полигоно Индустириал,
28108 Алкобендас (Мадрит) Испания



Recycling



ENVIRONMENTAL PROTECTION: Please recycle any unwanted materials as opposed to disposing them as general waste. It is recommended the original is retained and used to store the product when not in use for prolonged periods of time. If this is not applicable ensure the materials are sorted and recycled in accordance with local regulations.



SPECIFICATION CHANGE: It is our policy to continually improve products to ensure these meet the rigours of the industry we serve. Therefore, as such we reserve the right to alter specifications, data, components & parts with-out prior notice.

WARRANTY: Please refer to the manufactures terms & conditions.

IMPORTANT: No liability will be accepted for the incorrect use of this product.

KEEP THIS BOOKLET FOR FUTURE REFERENCE

📞 Nottingham: 0115 946 1988 • London: 0208 830 3333 ✉ Nottingham: sales@hscgroupuk.co.uk • London: sean@hscgroupuk.co.uk 🌐 www.hscgroupuk.co.uk

The Hire Supply Company Terms & Conditions Apply At All Time E&OE